

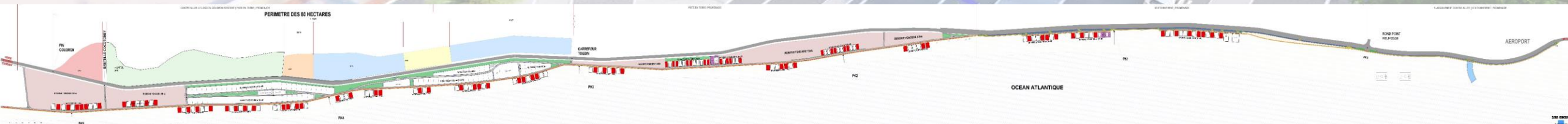

Ver.9 – Janvier 2023

AMÉNAGEMENT DE 12,5 KM DU LITTORAL

SECTION MARIE STELLA – ADOUNKO



SOMMAIRE

L'AMENAGEMENT

LES EQUIPEMENTS STRUCTURANTS

LE LOTISSEMENT COMMERCIAL

LES RESTAURANTS

LA MISSION DE CONTROLE

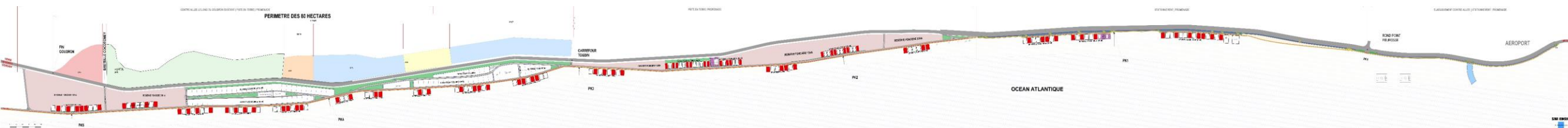



Ver.9 – Janvier 2023

L'AMENAGEMENT

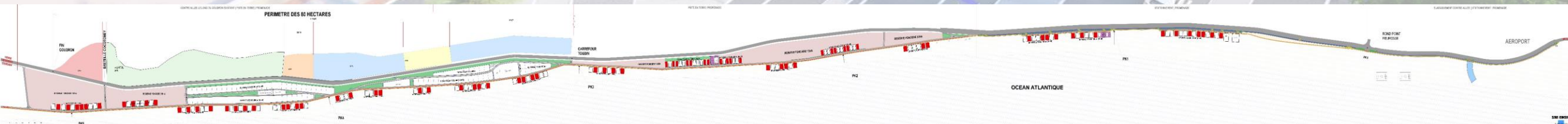

PRINCIPES D'AMENAGEMENT

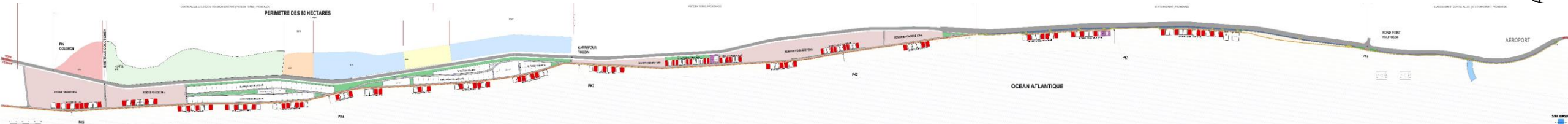

AMÉNAGEMENTS URBAINS

PISTE CYCLABLE - PROMENADE

ALIGNEMENT DE COCOTIERS LE LONG DE LA ROUTE

POINTS KILOMÉTRIQUES TOUS LES DEUX KILOMETRES

150 PARCELLES COMMERCIALES SUR LA PLAGE

02 PARCS SPORTIFS

OUVERTURE D'AU MOINS 40% DE FACADE MARITIME

AMÉNAGEMENTS ROUTIERS

PLACES DE STATIONNEMENT LE LONG DE LA ROUTE

RÉHABILITATION DE L'ANCIENNE ROUTE EN TERRE STABILISÉE

EXTENSION DE LA CONTRE ALLÉE À PARTIR DE TOGBIN

ENVIRONNEMENT

VÉGÉTATION EXISTANTE ESSENTIELLEMENT DES COCOTIERS (25 HECTARES)

RENFORCEMENT DES COCOTERAIES EXISTANTES (15 HECTARES)

PLANTATION DE NOUVEAUX COCOTIERS (60 HECTARES)

FONCIER

PARCELLAIRE COMMERCIAL: 16HECTARES

RESERVES FONCIERES (37 HECTARES)

ZONES	QUARTIER	DESIGNATION	LONGUEUR
ZONE 1	FIYEGNON	MARIE STELLA – ROND POINT	1,6 KM
ZONE 2	FIDJROSSE	ROND POINT - EMBRANCHEMENT	3,1 KM
ZONE 3	TOGBIN - ADOUNKO	LA PISTE ET SES BRETelles	8,3 KM
ZONE 4	TOGBIN - ADOUNKO	EXTENSION CONTRE ALLEE	7,5KM
TOTAL			20,5 KM

PARCELLAIRE COMMERCIAL

QUARTIERS	1200	800	TOTAL
FIYEGNON DJAKO	0	0	0
FIYEGNON HOUTA	40	0	40
TOGBIN DAHO	50	10	60
ADOUNKO	10	40	50
TOTAL	100	50	150

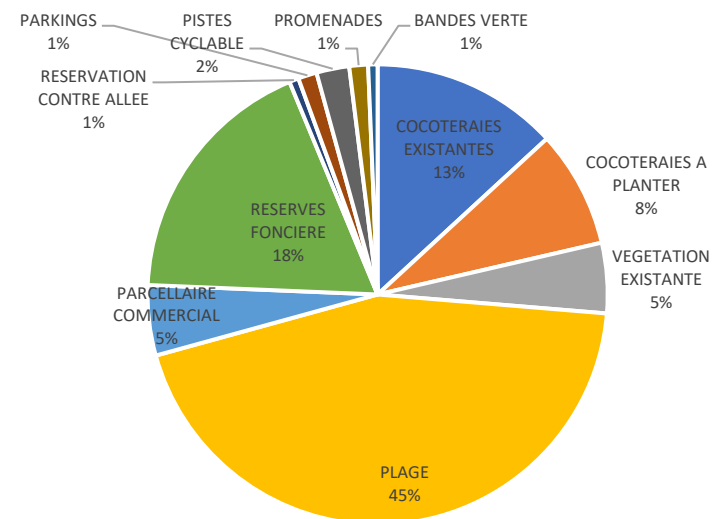

SARA CONSULT

Architectures & Ingénieries

ZONE 1

Fiyégnon 1
Marie Stella – Rond Point (1,6 KM)

AMÉNAGEMENTS

DÉPART PROMENADE ET PISTE CYCLABLE (1,5KM)

AMÉNAGEMENT DU BASSIN

CONSTRUCTION D'UN PONT SUR LE PARCOURS
COCOTERAIE

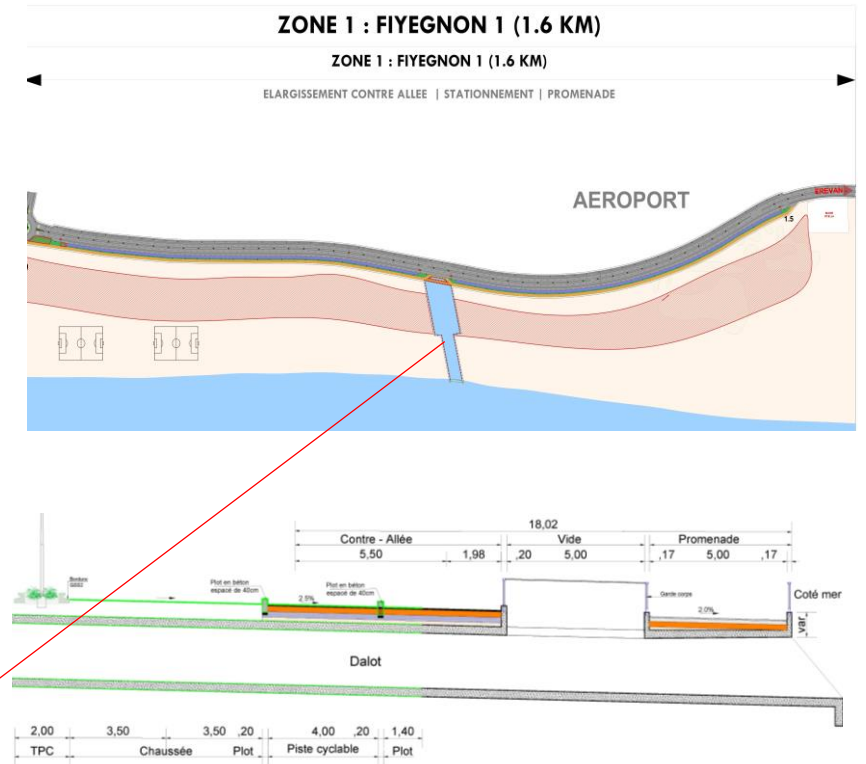
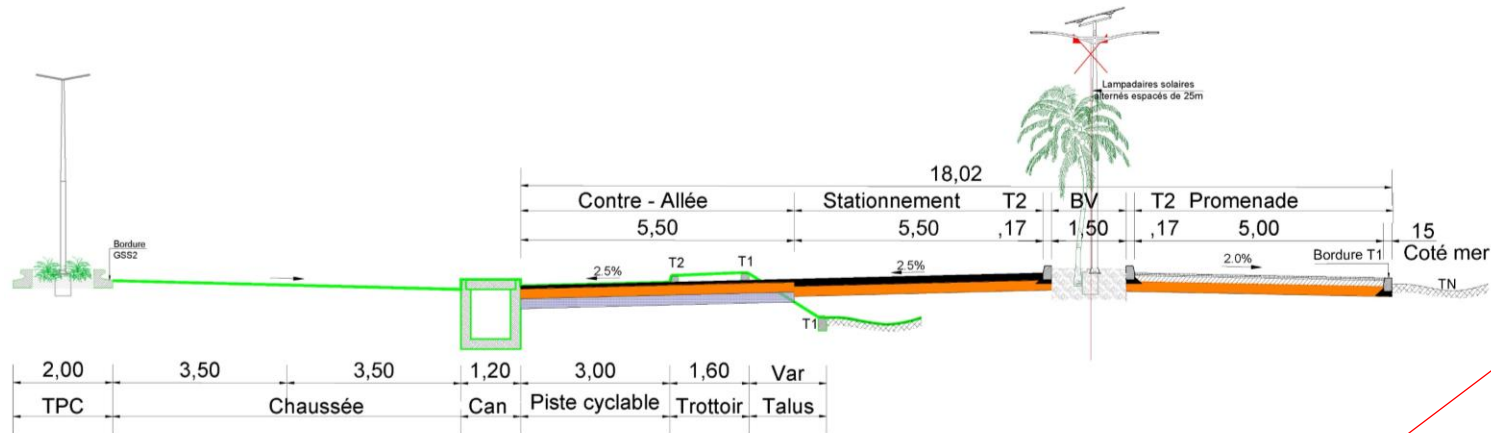

DÉPART MARIE STELLA



LE BASSIN EN FACE DE L'AÉROPORT



PONT SUR LE BASSIN



ZONE 2

Fiyégnon 2
Rond Point - Embranchement (3,2 KM)

AMÉNAGEMENTS

- PROMENADE ET PISTE CYCLABLE (3,2KM)
- TRAVERSEE DE LA COCOTERAIE PAR LA PROMENADE
- COCOTERAIE A PLANTER (EN ROUGE)
- 01 POINT KILOMETRIQUE
- 02 ZONES D'EXPERIMENTATION
- PARC SPORTIF 4.000M²

FONCIER

PARCELLAIRE COMMERCIAL: 22 DE 2400M² - 18 DE 1200M²

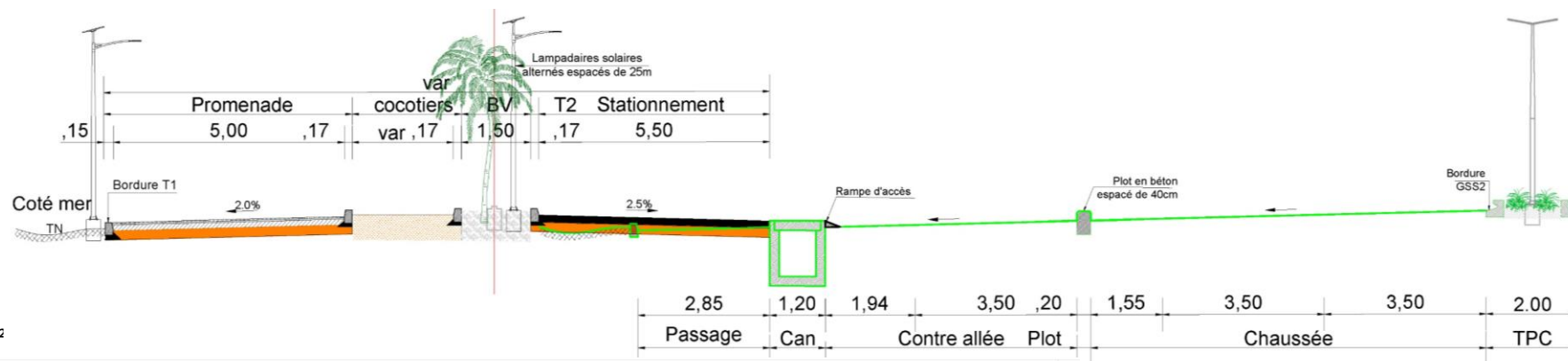

ZONE 2 : FIYEGNON HOUTA (3.2 KM)

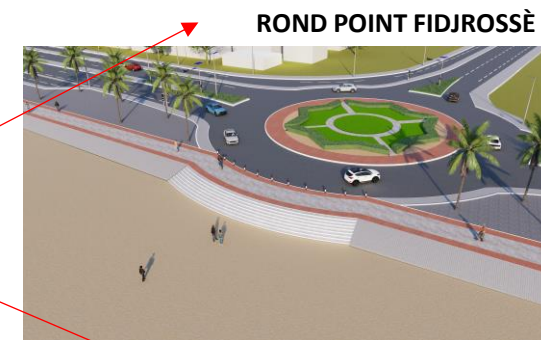
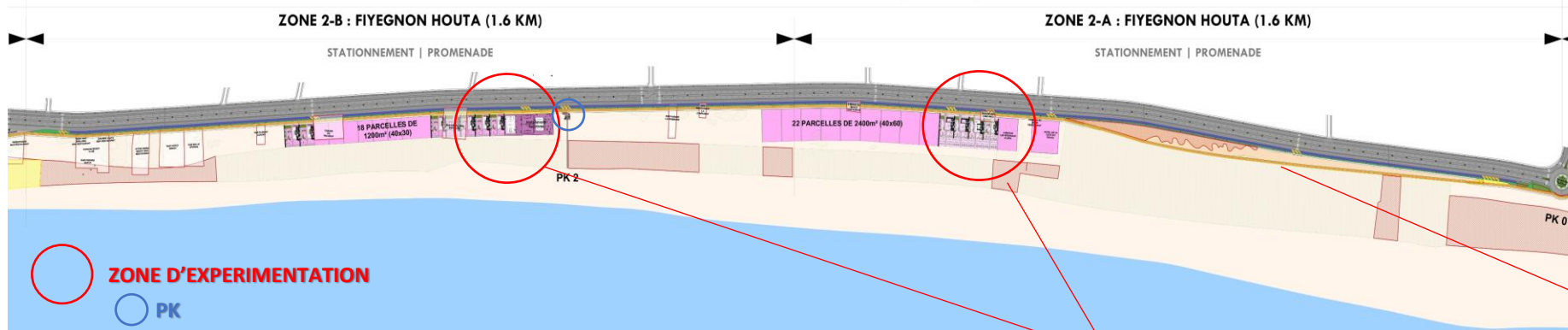

PARC SPORTIF



ZONE D'EXPERIMENTATION



TRAVERSEE DE LA COCOTERAIE



ZONE 3 - 4

Togbin – Adounko
Embranchement - Fin goudron (7,5Km)

AMÉNAGEMENTS

- L'EMBRANCHEMENT DES DEUX ROUTES
- PISTE EN TERRE TES BRETLES (8,3KM)
- CONTRE ALLEE (7,5KM)
- PROMENADE ET PISTE CYCLABLE (7,5KM)
- COCOTERAIE A PLANTER (ROUGE)
- COCOTERAIE A RENFORCER (JAUNE)
- 04 POINTS KILOMETRIQUES (AIRES DE REPOS - MOBILIER URBAIN)
- LOTISSEMENT TOGBIN (K&D)
- ZONE D'EXPERIMENTATION + PARC SPORTIF 4.000M²
- STATIONNEMENT DEVANT LES ILOTS COMMERCIAUX

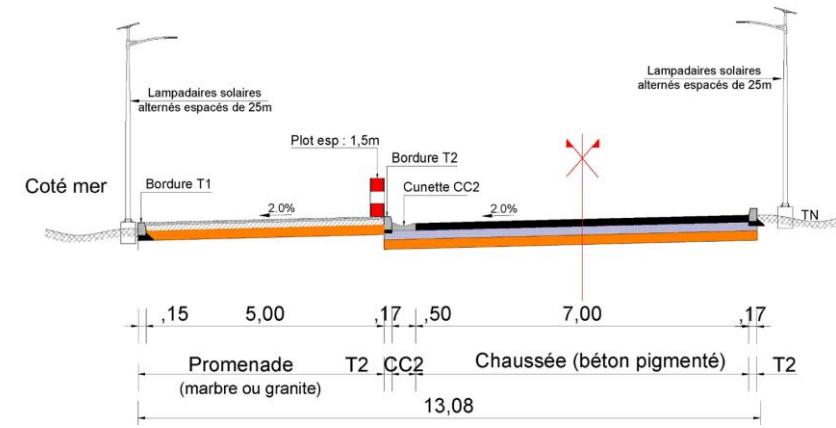
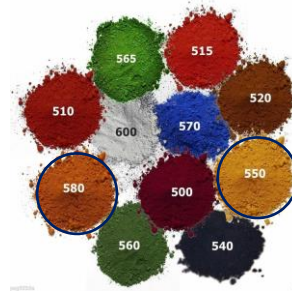

FONCIER

PARCELLAIRE COMMERCIAL: 10 DE 2400M² - 50 DE 1200M² - 50 DE 600M²
RESERVES FONCIERES 37 Ha



EMBRANCHEMENT



PISTE EN TERRE



CONTRE ALLEE



ZONE 3 - 4

Togbin – Adounko
Embranchement - Fin goudron (7,5Km)

AMÉNAGEMENTS

- L'EMBRANCHEMENT DES DEUX ROUTES
- PISTE EN TERRE (8,3KM)
- CONTRE ALLEE (7,5KM)
- PROMENADE ET PISTE CYCLABLE (7,5KM)
- COCOTERAIE A PLANTER (ROUGE)
- COCOTERAIE A RENFORCER (JAUNE)
- 04 POINTS KILOMETRIQUES
- LOTISSEMENT TOGBIN
- ZONE D'EXPERIMENTATION + PARC SPORTIF 4.000M²
- STATIONNEMENT DEVANT LES ILOTS COMMERCIAUX

FONCIER

- PARCELLAIRE COMMERCIAL: 10 DE 2400M² - 50 DE 1200M² - 50 DE 600M²
- RESERVES FONCIERES 37 Ha

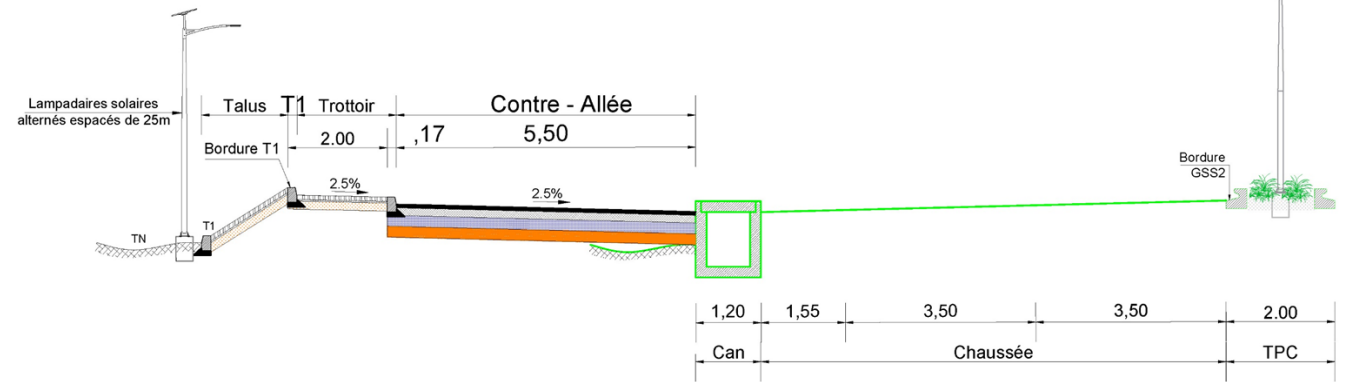
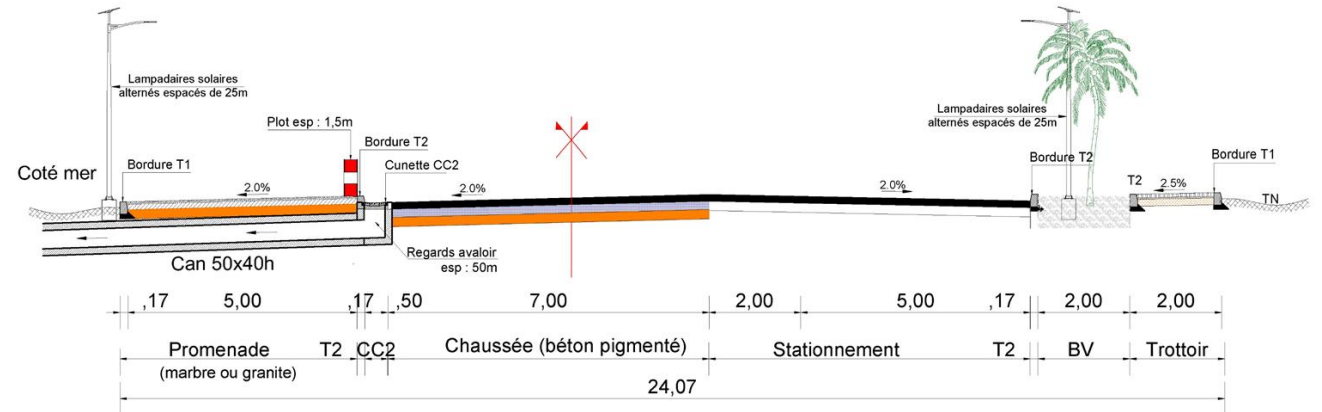

LOTISSEMENT TOGBIN





Ver.9 – Janvier 2023

LES EQUIPEMENTS STRUCTURANTS

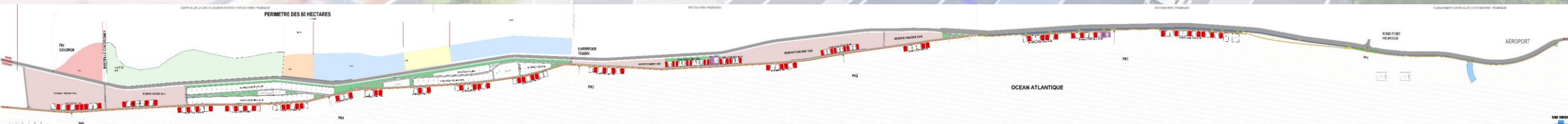

LE POINT KILOMETRIQUE

Elément structurant de la promenade, le **point kilométrique** est un arrêt tous les deux kilomètres le long du parcours. Il permet une flexibilité et une structuration du parcours en prévoyant deux kiosques et des toilettes publiques. C'est bâtiment du format de deux conteneurs de 20'' qui se font dos, l'un coté plage et l'autre coté route. Il donne accès à la plage via un platelage en bois.

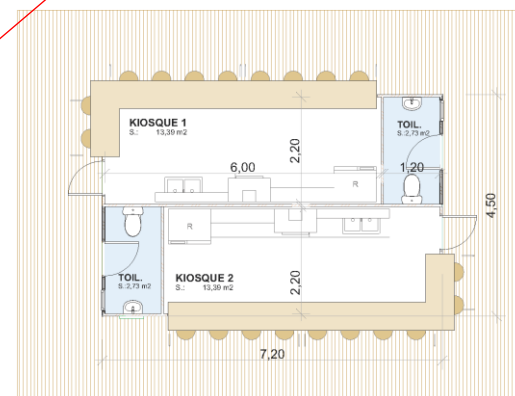
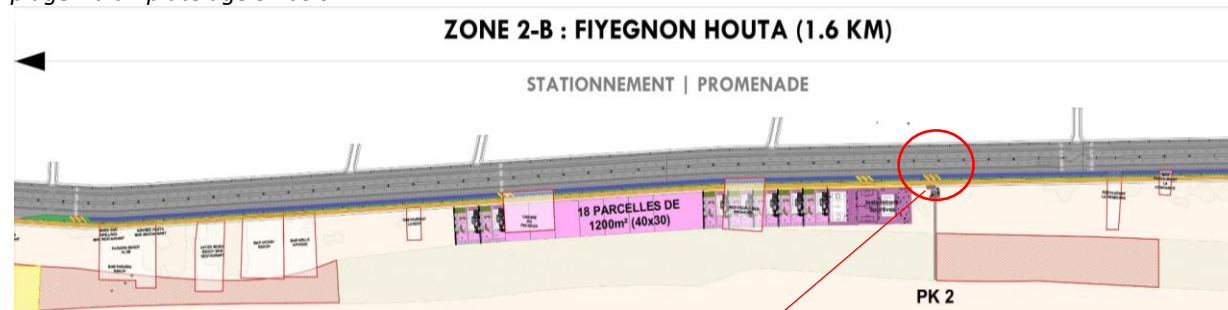

LA PROMENADE

*Large de 5 mètres, elle fait office de trottoir et de piste cyclable coté plage.
Elle sera revêtue en granite ou en carreaux.*



LES EXUTOIRES SERONT AMENAGÉS EN BASSIN D'INFILTRATION LE LONG DE LA PROMENADE COTE PLAGE





Ver.9 – Janvier 2023

LE LOTISSEMENT COMMERCIAL

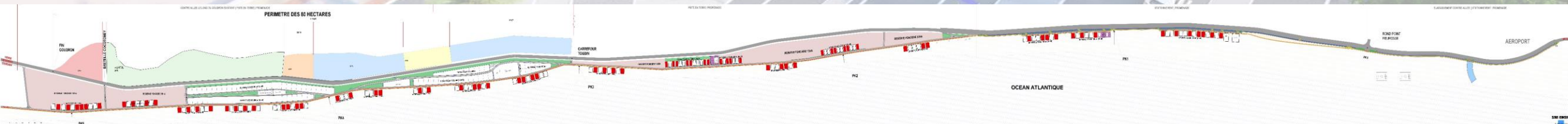

ILOT 1

14 Parcelles de 1200m²

NORD

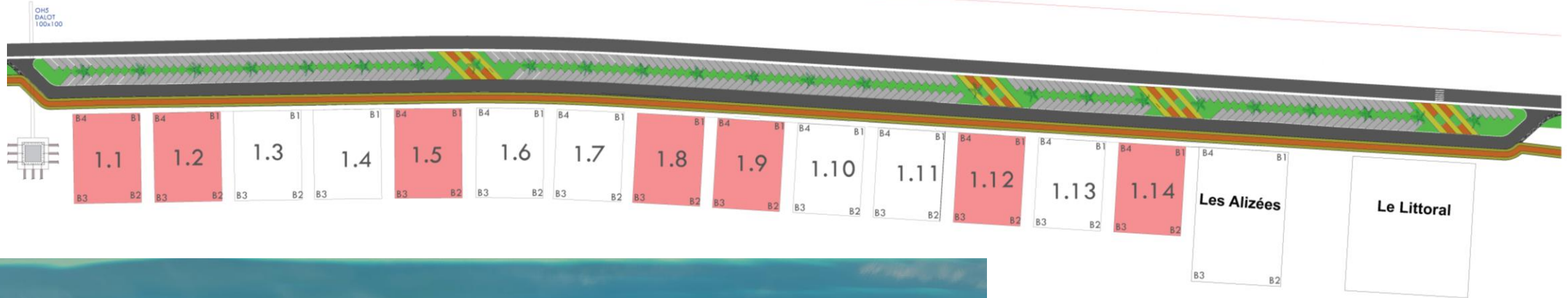

ZONE 2 : FIYEGNON HOUTA (3.2 KM)

STATIONNEMENT | PROMENADE

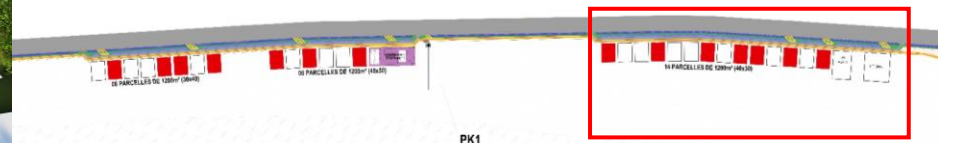

ILOT 2 - 3

12 Parcelles de 1200m²

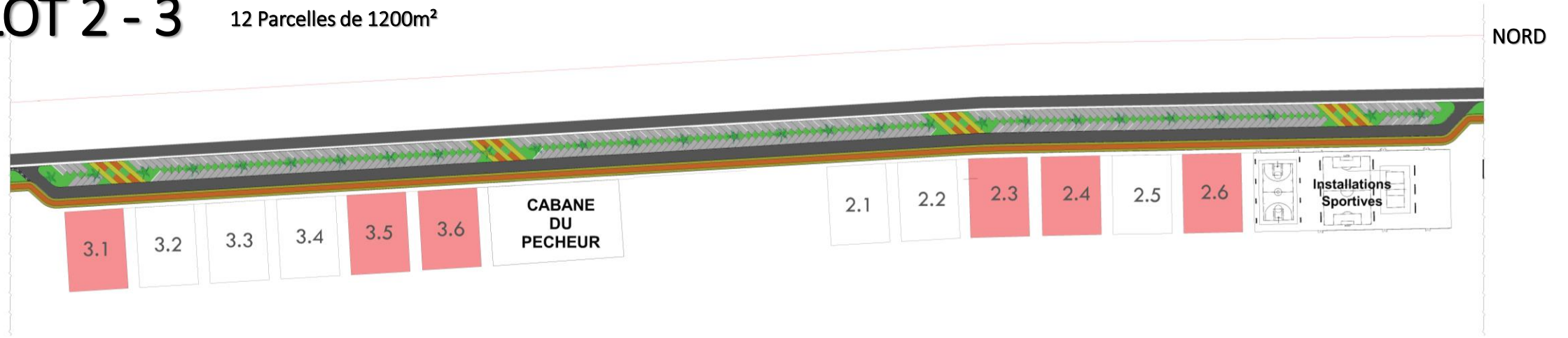

ZONE 2 : FIYEGNON HOUTA (3.2 KM)

STATIONNEMENT | PROMENADE

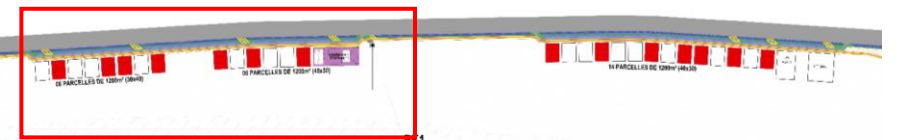

ILOT 4

06 Parcelles de 1200m²

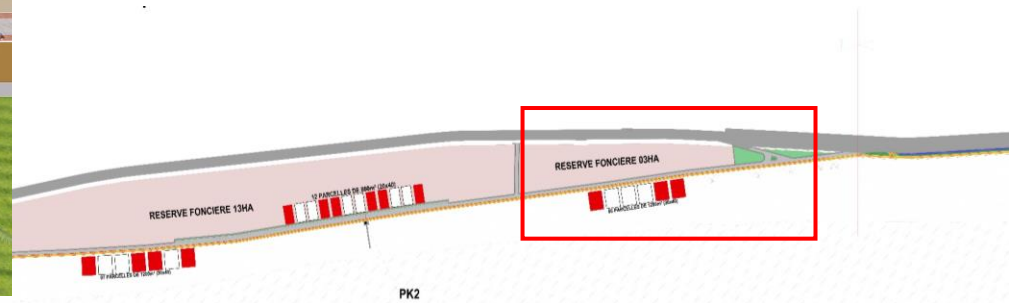
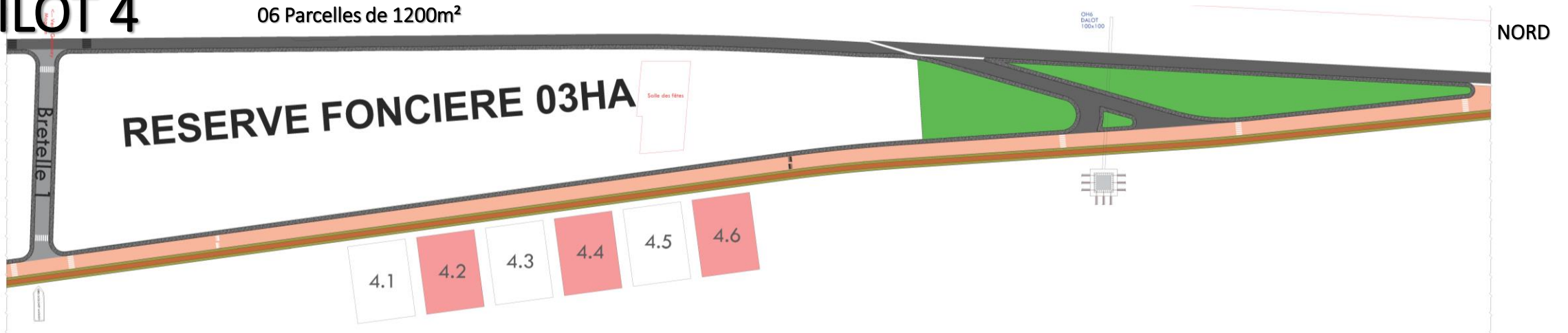

ILOT 5

12 Parcelles de 800m²

RESERVE FONCIERE 10HA

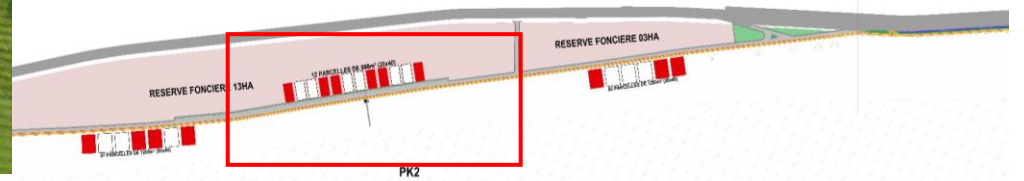
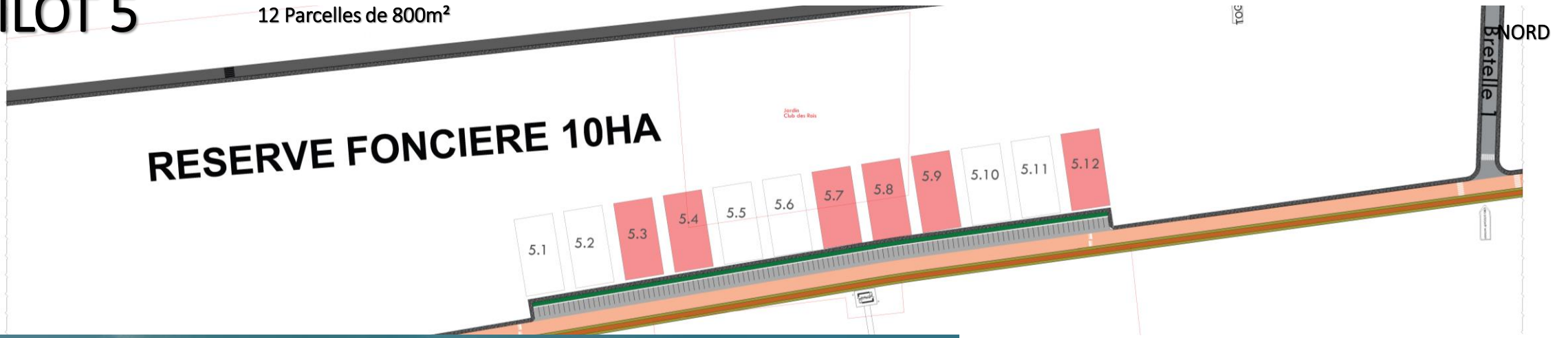

ILOT 6 - 7

07 Parcelles de 1200m² & 12 de 800m²

NORD

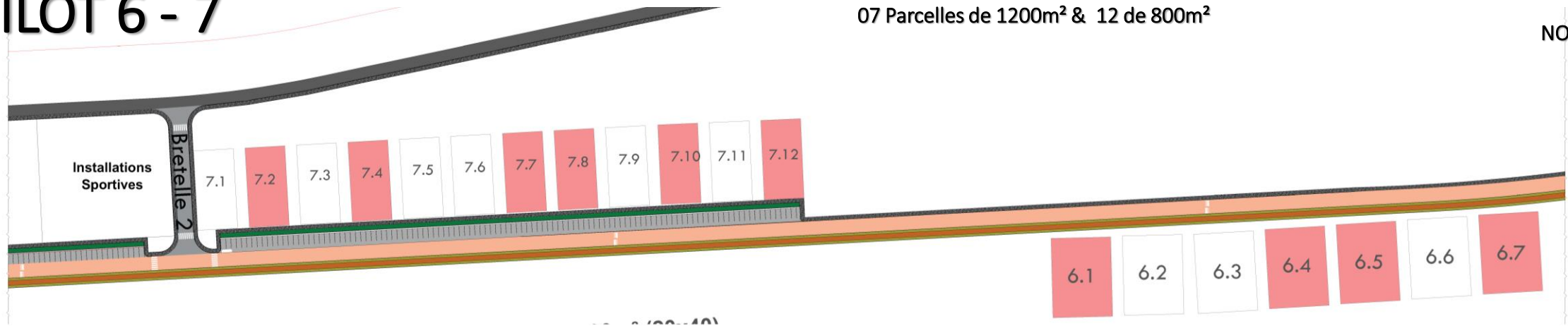

ILOT 8

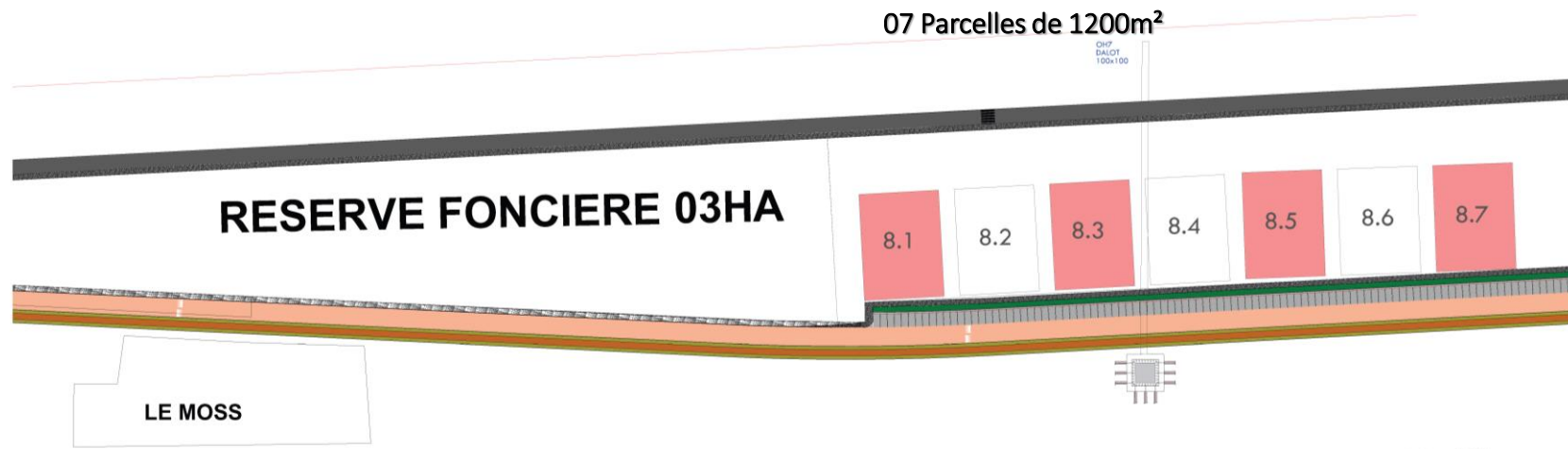

NORD



ILOT 9

08 Parcelles de 1200m²

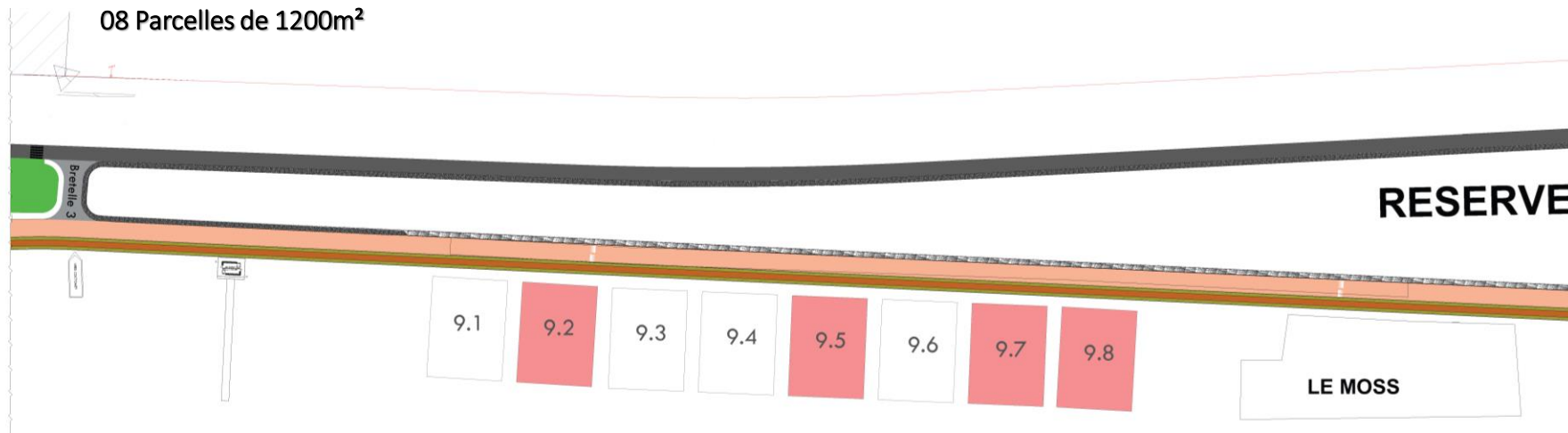

NORD

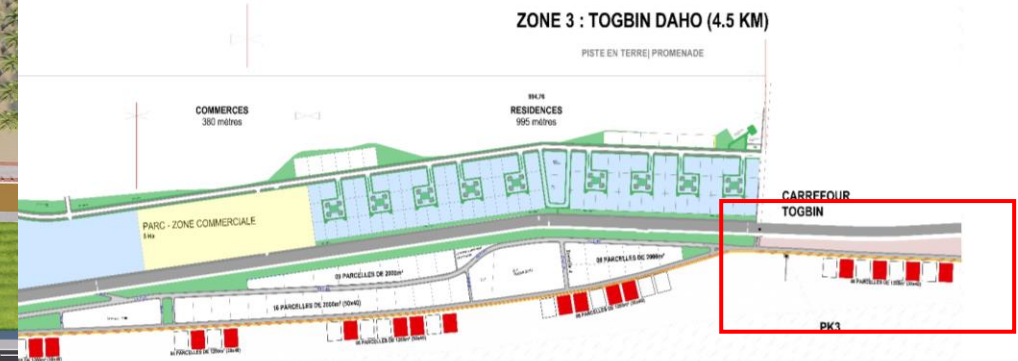
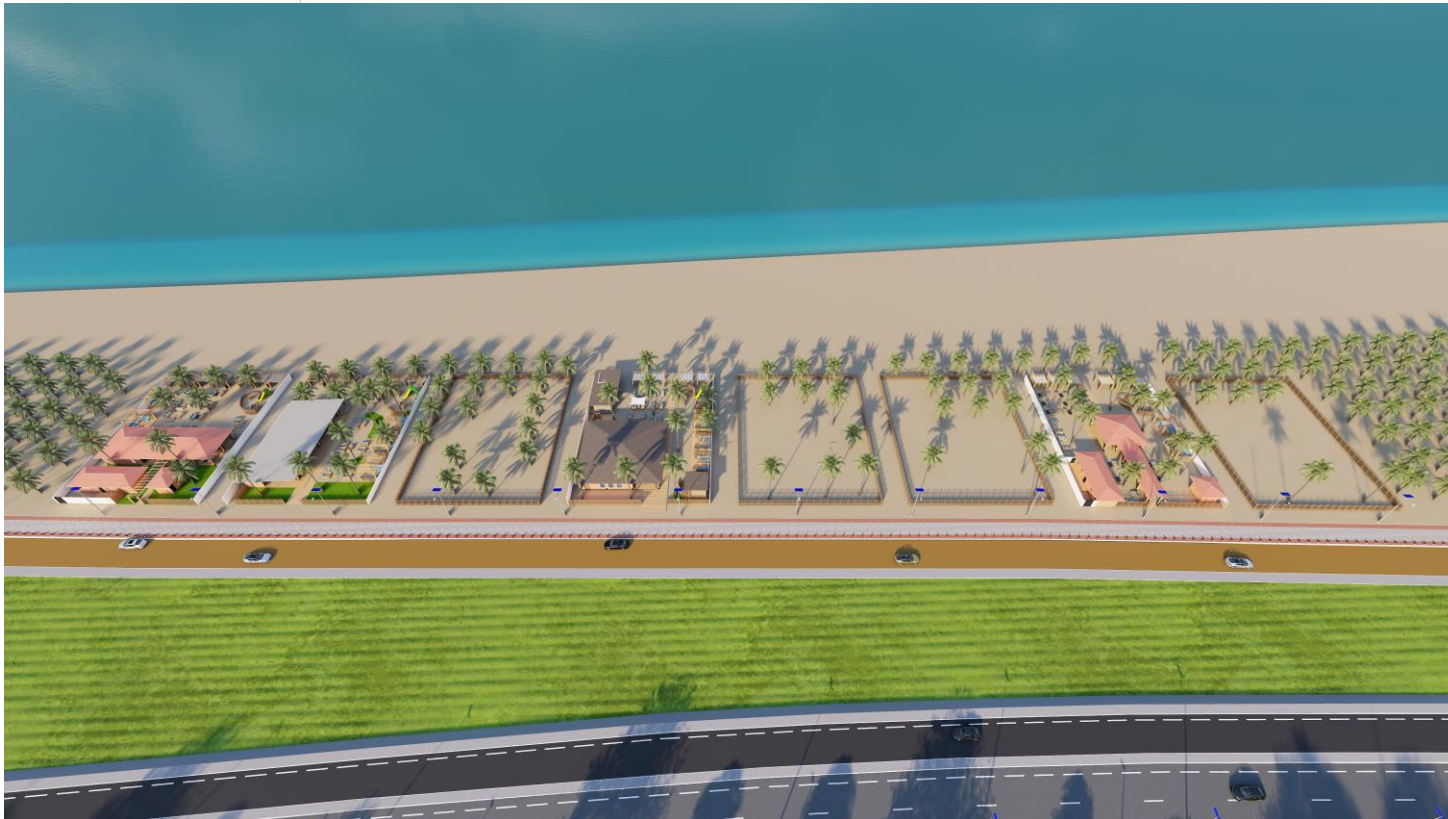

ILOT 10 - 11

12 Parcelles de 1200m²

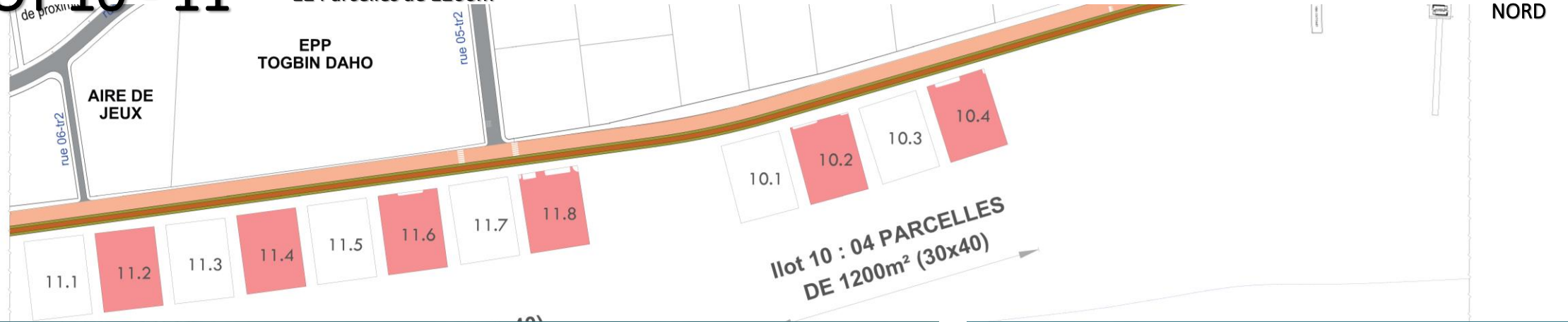

ILOT 12 - 13

12 Parcelles de 1200m²

NORD

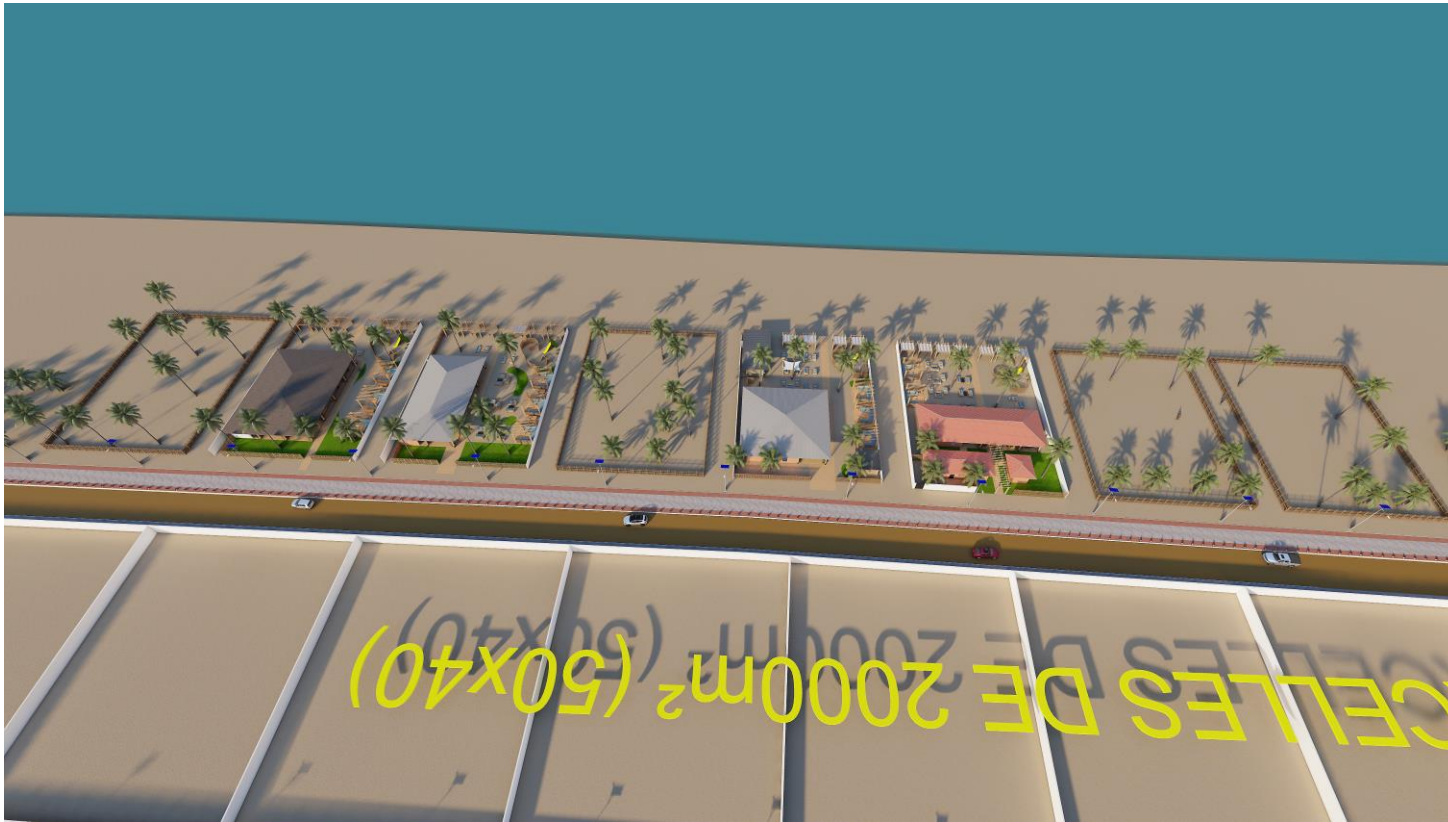
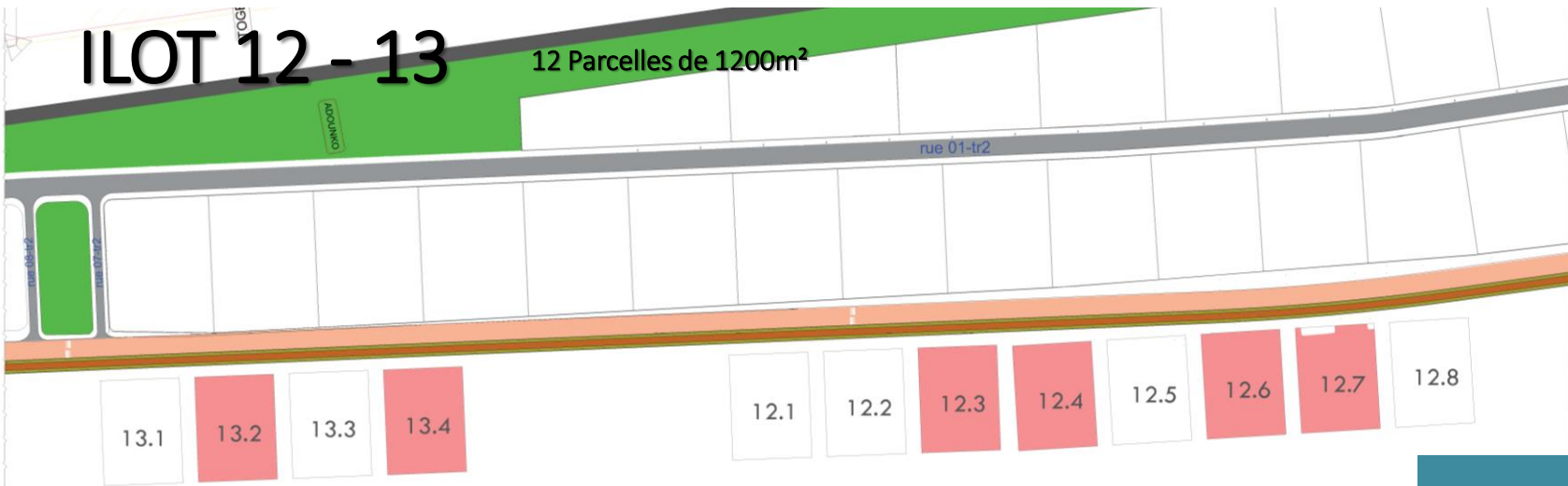

ILOT 14- 15

08 Parcelles de 1200m²

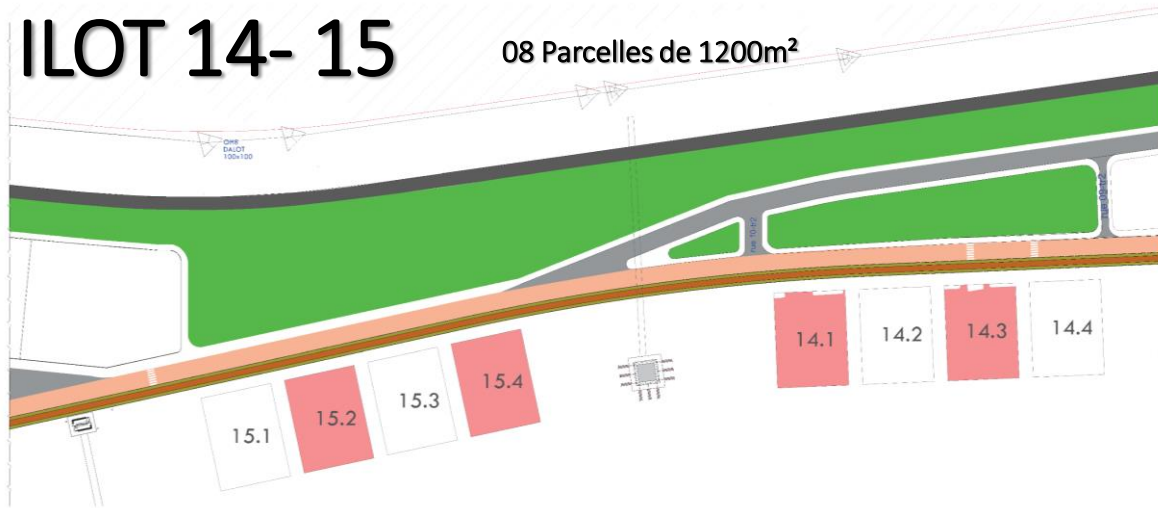

NORD

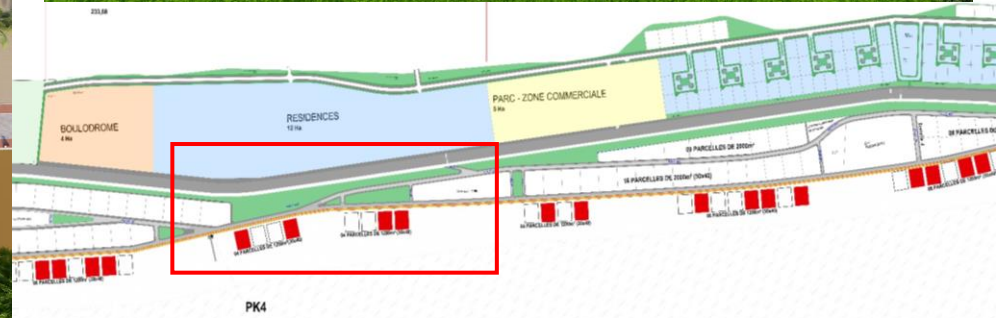
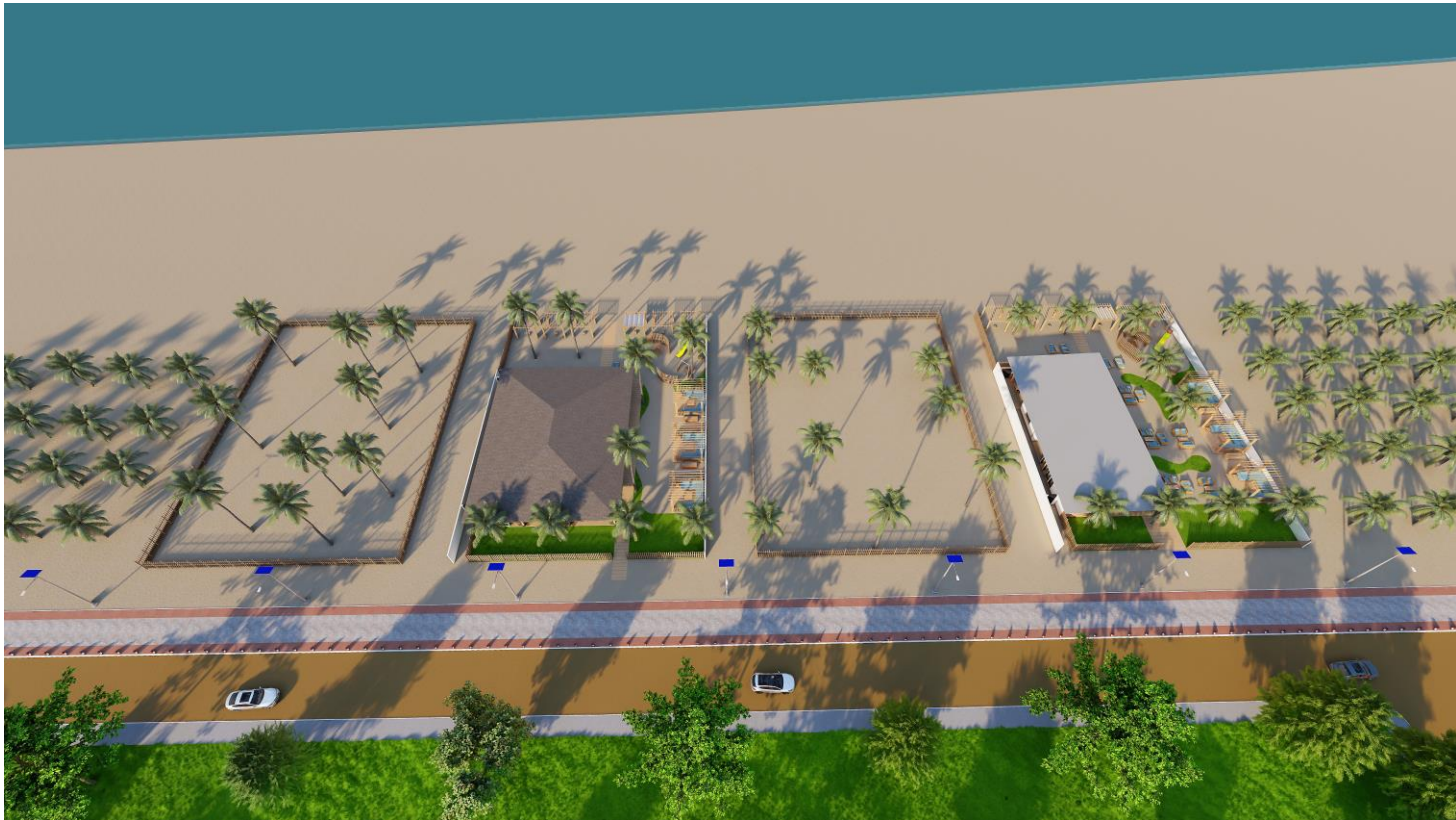

PK4

ILOT 16-17

NORD

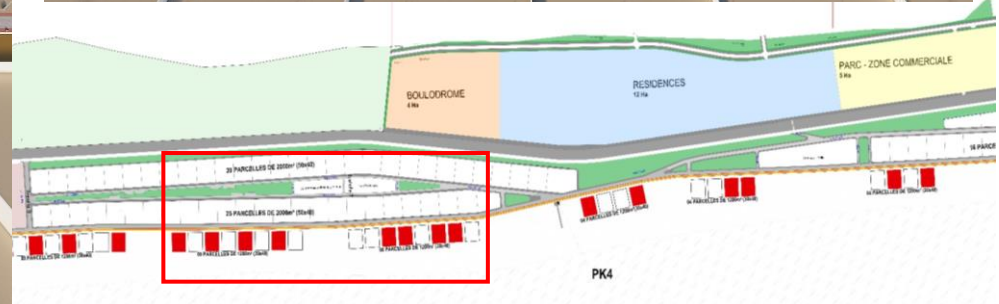
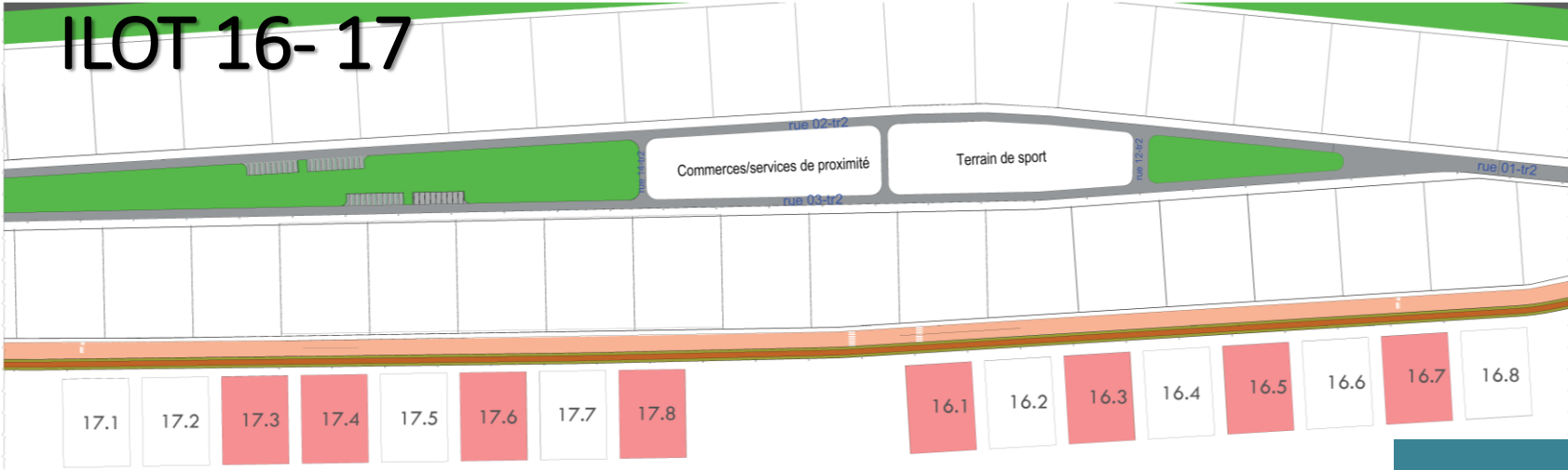

ILOT 18-19

RESERVE FONCIERE 08HA

Bretelle 4

NORD

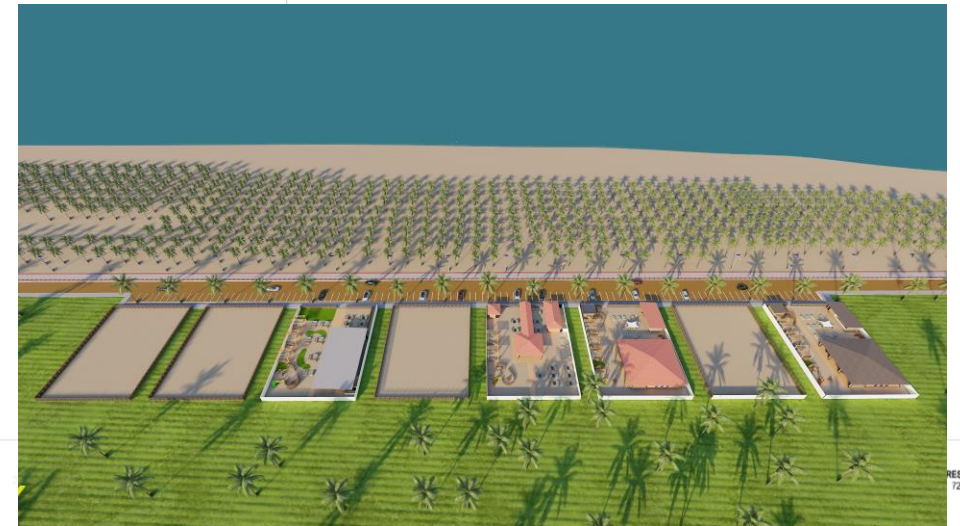
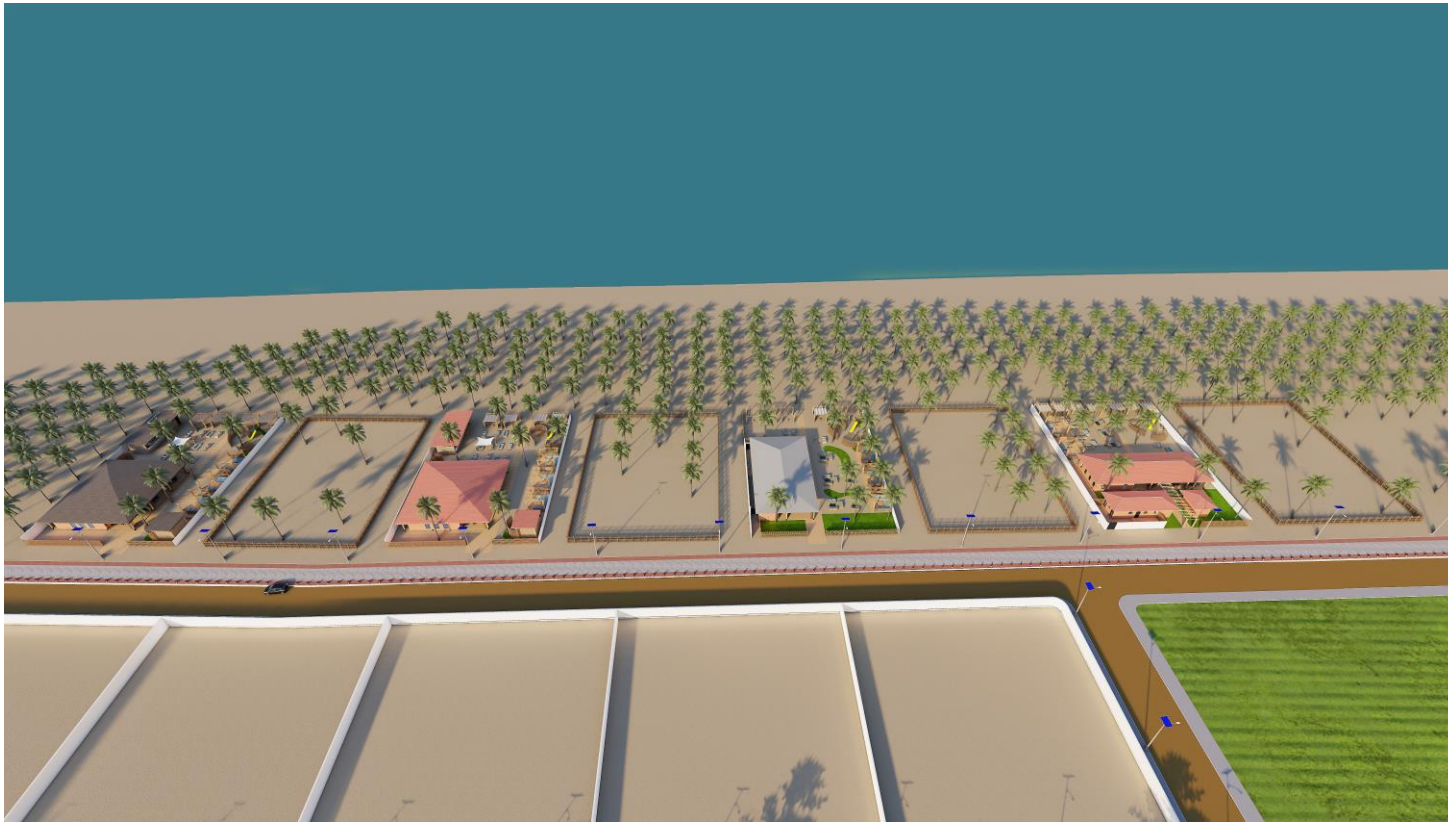
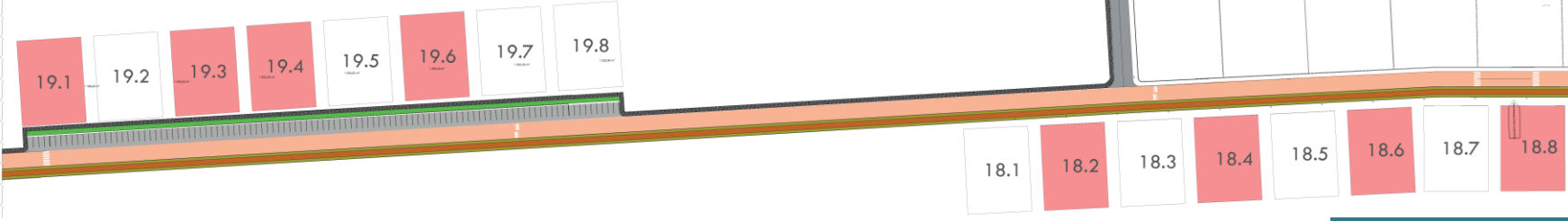

ILOT 20

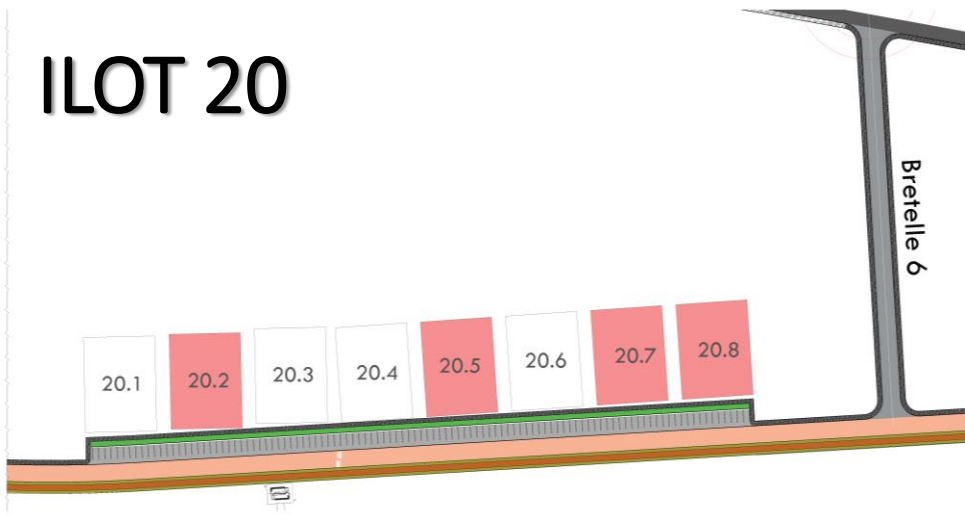

NORD

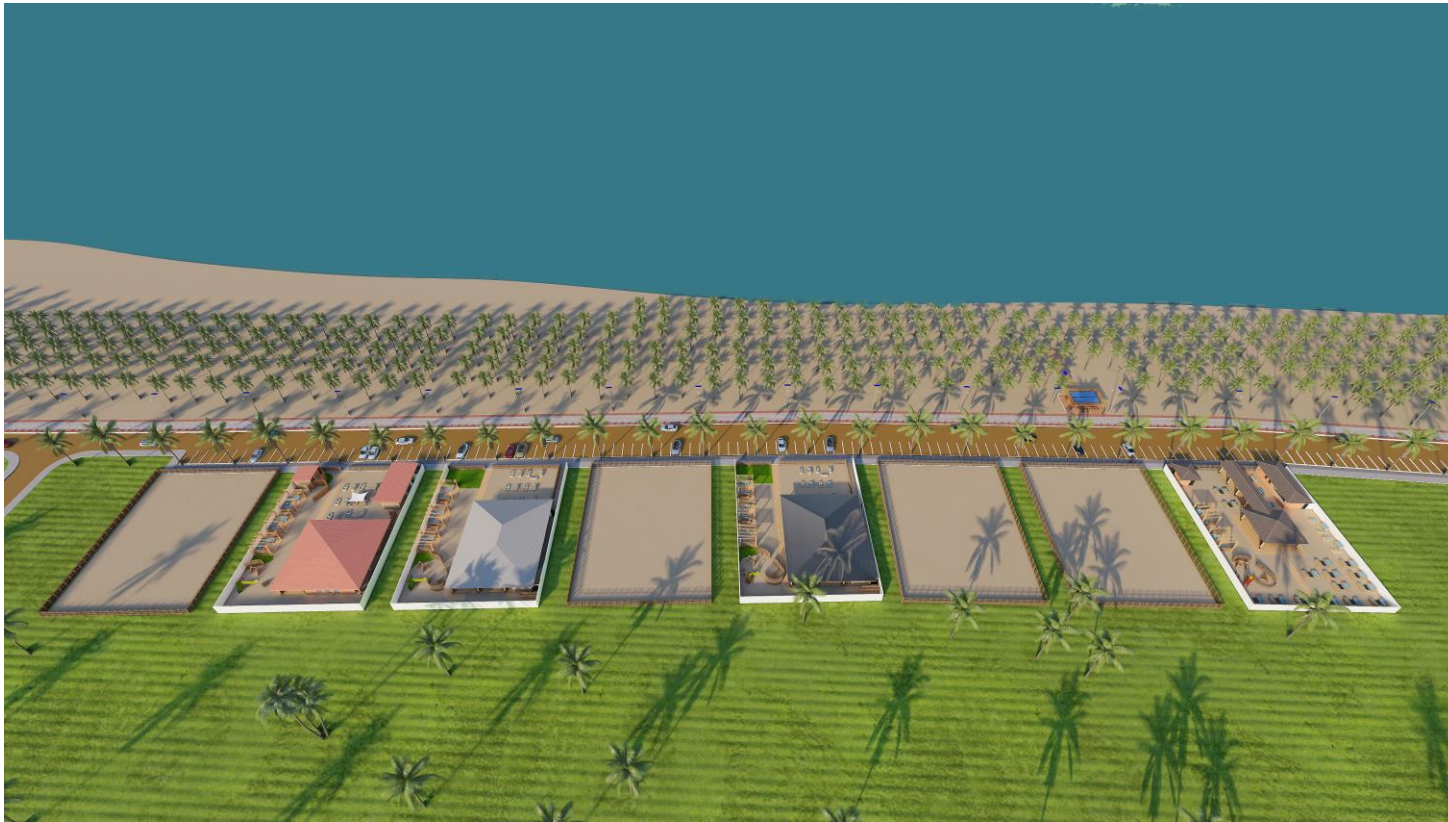

ZONE 4 : ADOUNKO (3.3 KM)

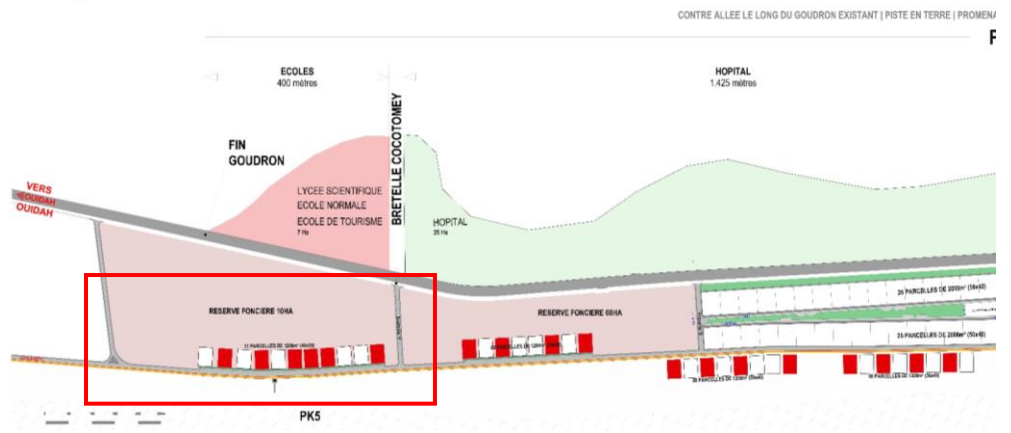



Ver.12 – Juillet 2023



LES RESTAURANTS



CONCEPT ARCHITECTURAL

CATEGORIES

On peut répartir les restaurants proposés en 3 catégories principales

MODELES PAILLOTE INTEGRALE

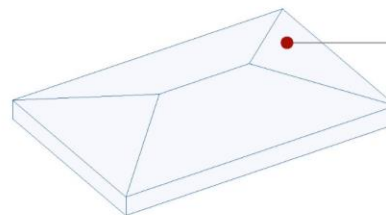

Une pailote intégrale abritant l'entièreté du programme du restaurant

Restauration
Bloc Technique
Bloc Sanitaire
Salle couverte
Terrasse

MODELES AMENAGES EN BLOCS DETACHES

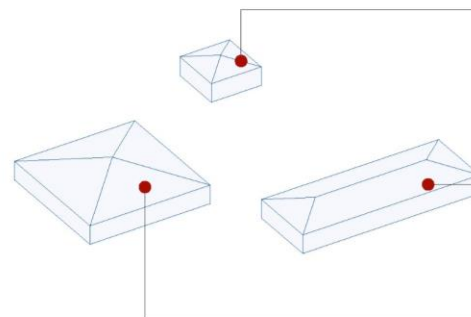

Bloc Sanitaire isolé

Bloc Technique isolé (avec la possibilité que le bloc sanitaire y soit directement intégré ou non)

Pailote principale abritant l'espace de restauration pouvant inclure un bar

MODELES A ETAGE AMENAGE EN TERRASSE

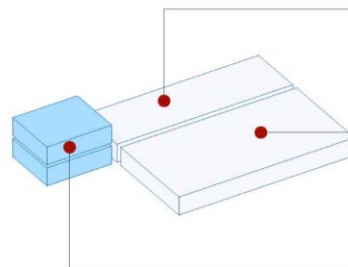

Bloc Technique

Restauration

Bloc Sanitaire couplé avec des escaliers menant à la terrasse accessible

CONCEPT ARCHITECTURAL

ORGANISATION SPATIALE

En fonction des trois catégories de restaurants indiquées ci-contre, différentes organisations spatiales ont été étudiées pour servir de base aux modèles de restaurants qui sont proposés

On pourra en outre remarquer la présence de modèles à salles et de modèles sans salles répartis à travers les 3 principales catégories des restaurants proposés

MODELES PAILLOTE INTEGRALE

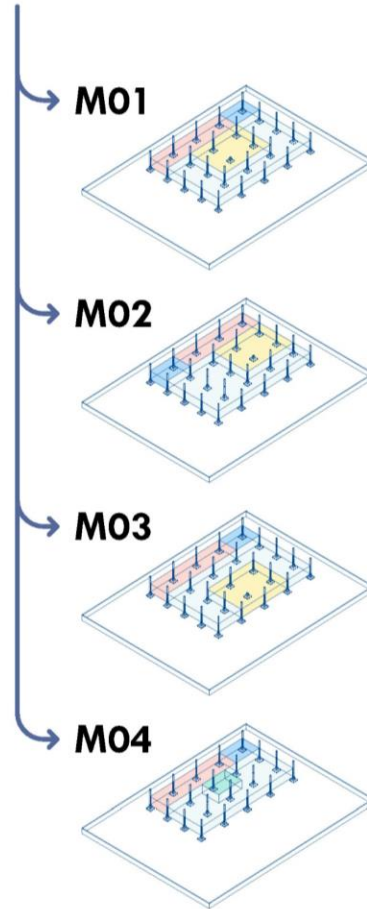

MODELES AMENAGES EN BLOCS DETACHES

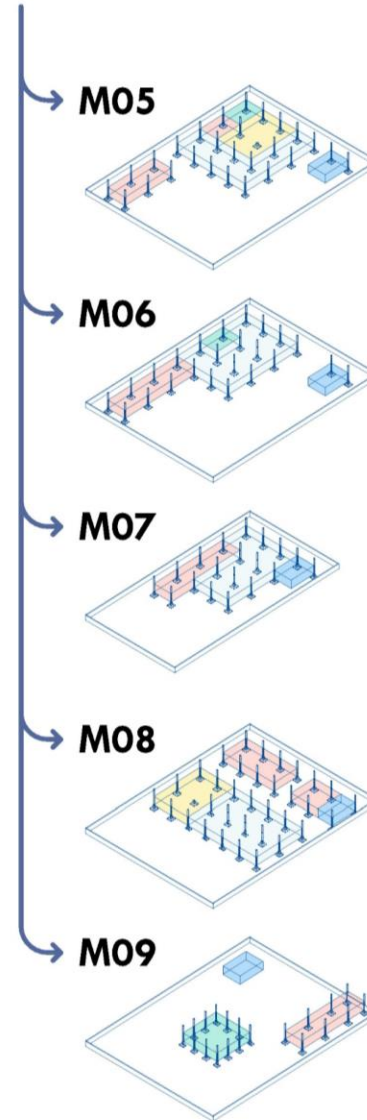

MODELES A ETAGE AMENAGE EN TERRASSE

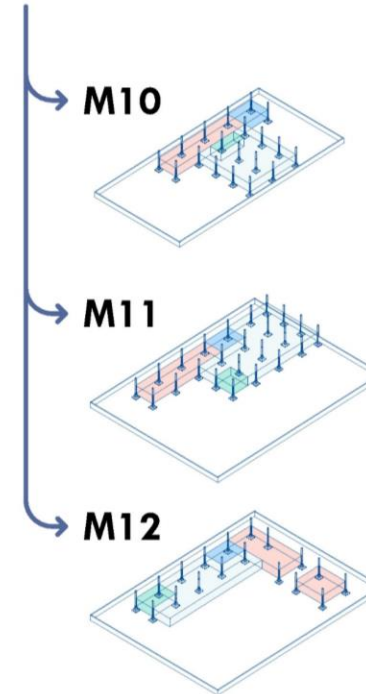

CONCEPT ARCHITECTURAL

DIVERSIFICATION DES MODELES

Après avoir arrêté 13 schémas de principe d'organisation spatiale différents, et vu l'impérativité de diversifier les restaurants proposés par leur volume et leur ambiance, les stratégies suivantes ont été adoptées.

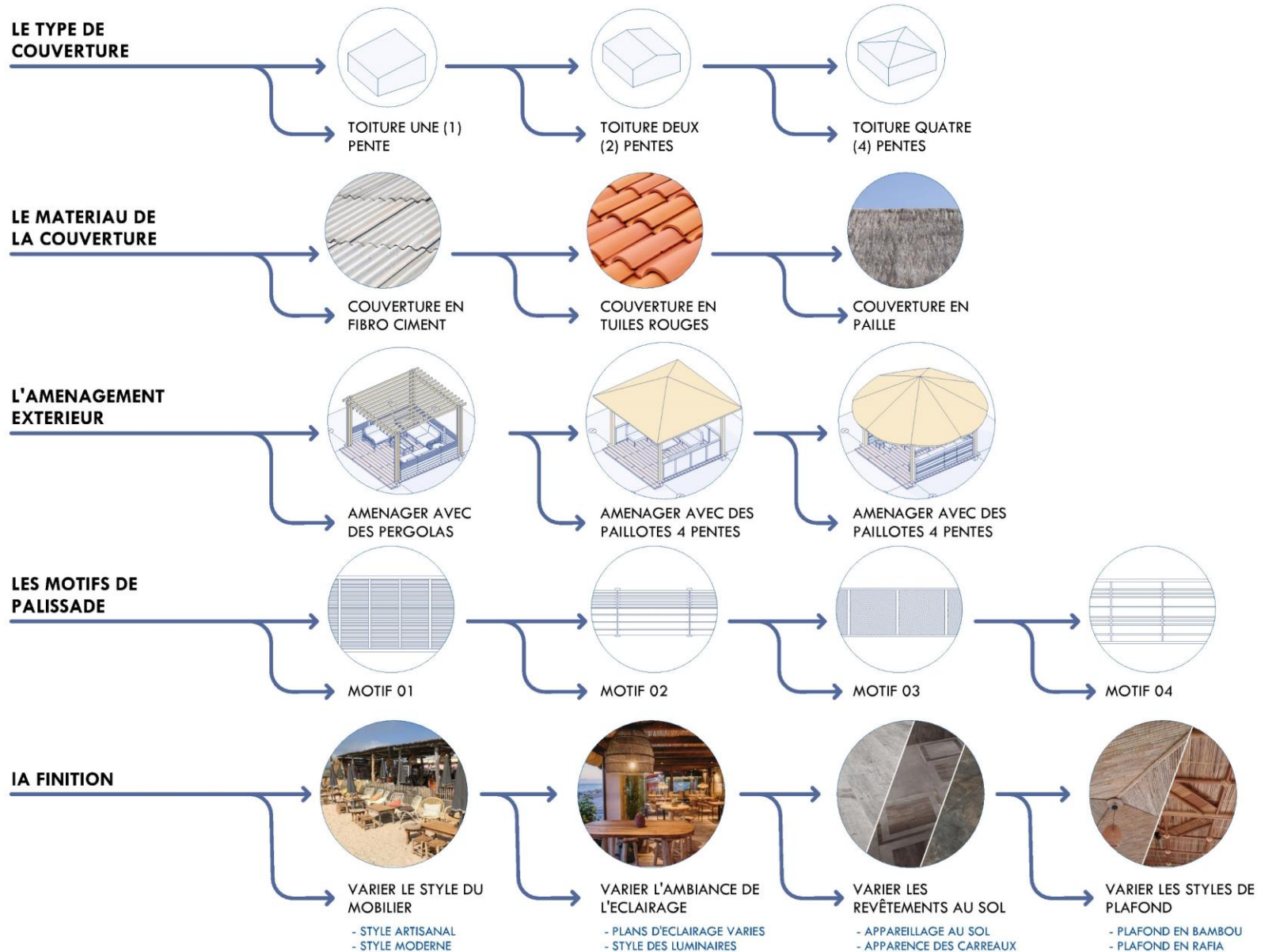

MODELE 01

PAILLOTE INTEGRALE

Paillote
 Salle fermée
Jardin en façade urbaine
 Toilette & cuisine intégrées sous
 la paillote

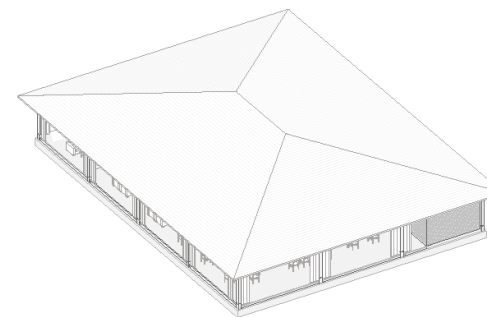
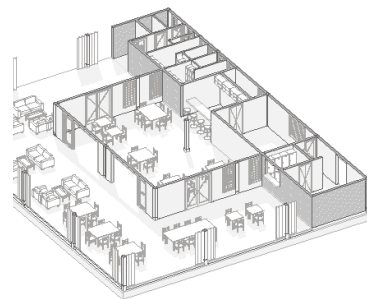
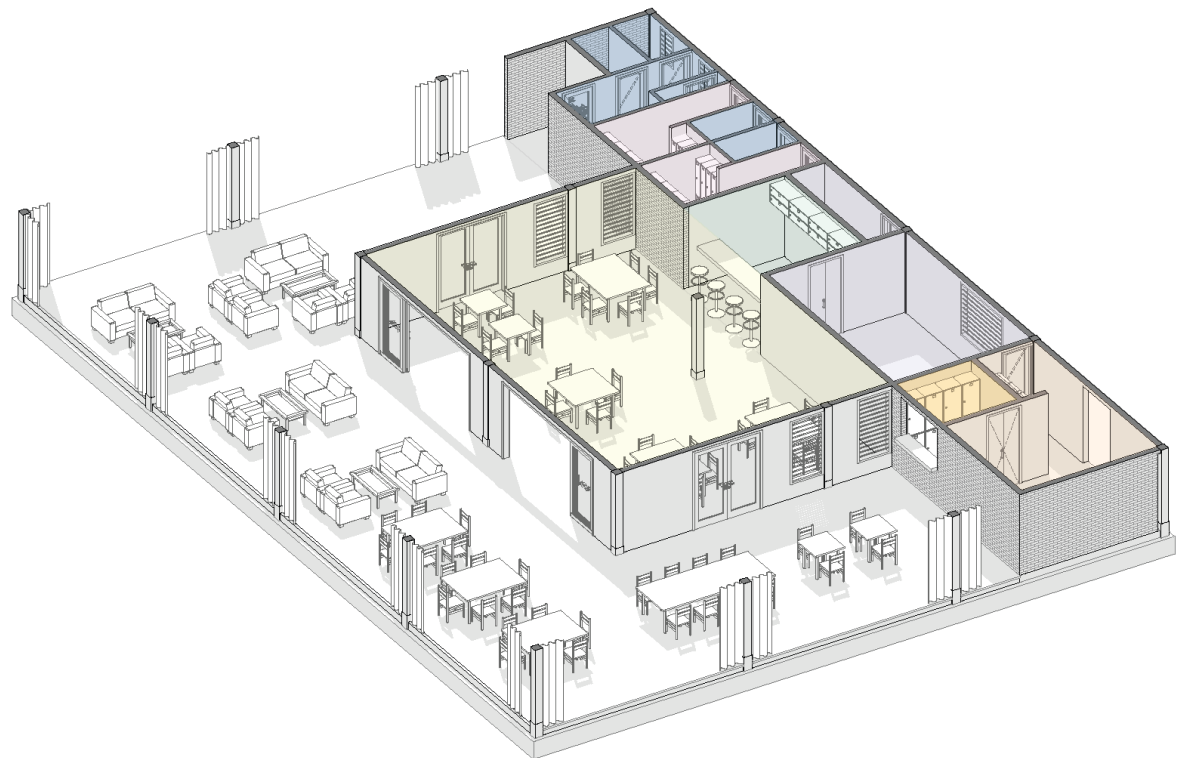

SARA CONSULT

Architectures & Ingénieries

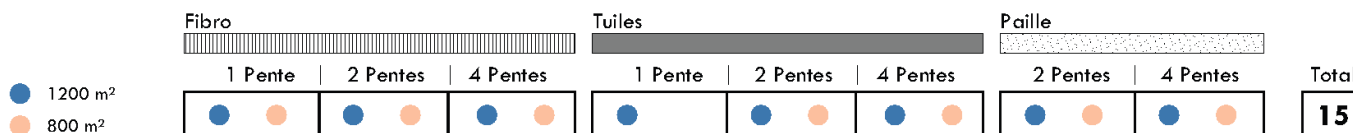

CONCEPT ARCHITECTURAL

- M01
- M02
- M03
- M04
- M05
- M06
- M07
- M08
- M09

MODELE 1

Paillote
Salle fermée
Jardin en façade urbaine
Toilette & cuisine intégrées sous la paillote



MODELE 1

Toiture 4 Pentes
Fibro



SARA CONSULT

Architectures & Ingenieries



MODELE 1

Toiture 4 Pentes
Tuiles Paille

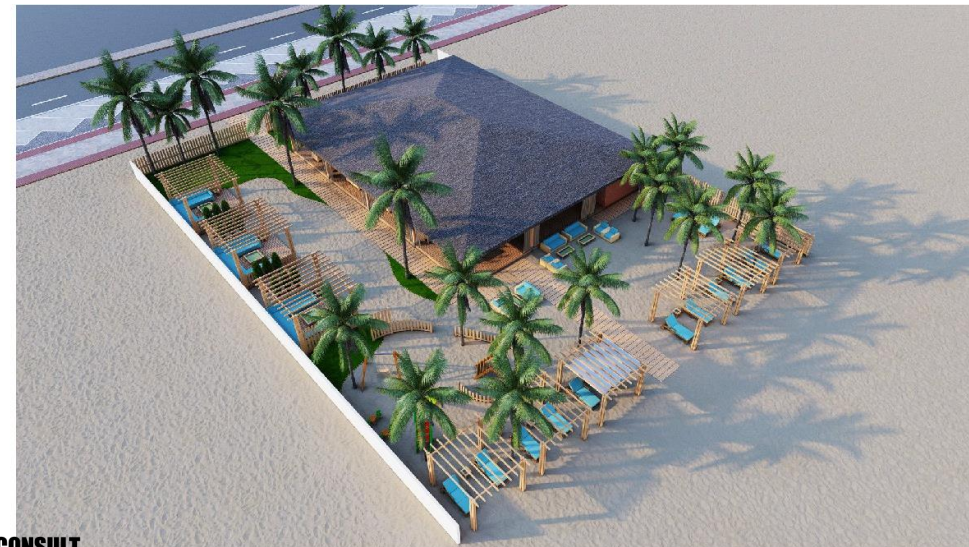

SARA CONSULT

Architectures & Ingenieries



MODELE 1

Toiture 4 Pentes
Tuiles Rouges



SARA CONSULT

Architectures & Ingenieries



MODELE 1

Toiture 2 Pentes
Paille



SARA CONSULT

Architectures & Ingenieries



MODELE 1

Toiture 2 Pentes
Fibro Ciment



SARA CONSULT



Architectures & Ingenieries



MODELE 1

Toiture 2 Pentes
Tuiles



SARA CONSULT

Architectures & Ingenieries



MODELE 1

Toiture 1 Pentes
Fibro Ciment



SARA CONSULT

Architectures & Ingenieries



MODELE 02

PAILLOTE INTEGRALE

Paillote
Salle fermée en façade urbaine
 Toilette & cuisine intégrées sous
 la paillote

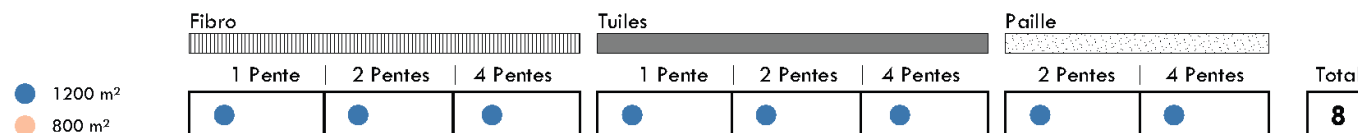
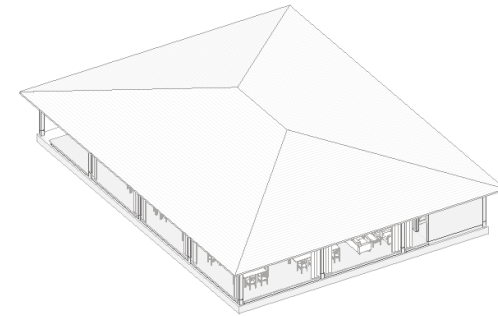
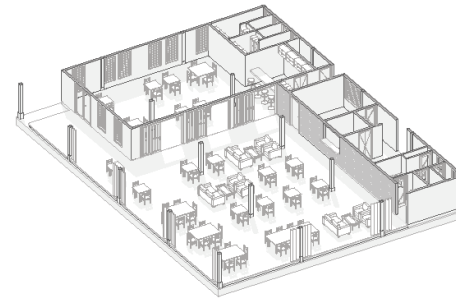
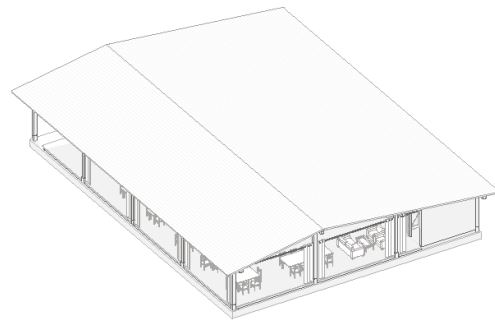

MODELE 2

Paillote

Salle fermée en façade urbaine

Toilette & cuisine intégrées sous la paillote



MODELE 2



SARA CONSULT

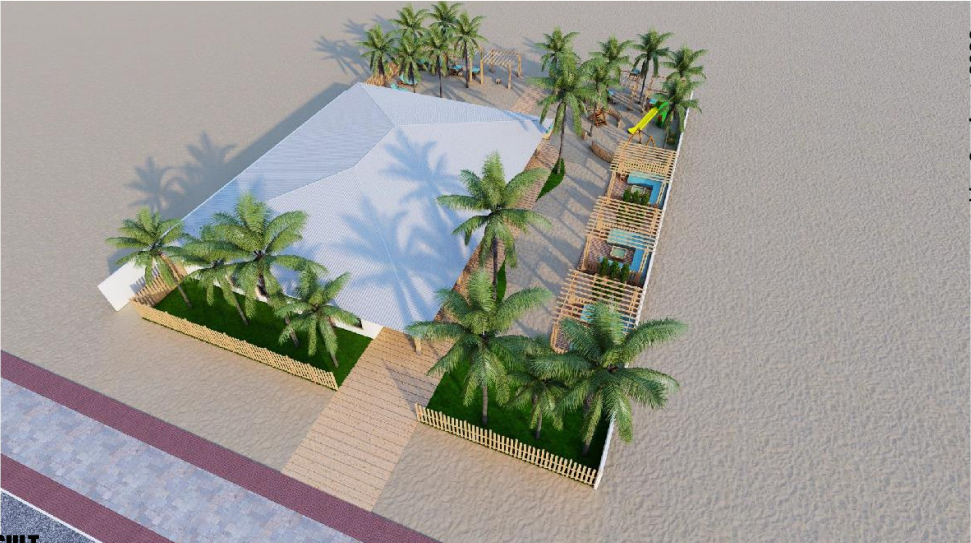

Ver.6 - Aout 2022



Architectures & Ingenieries



MODELE 2

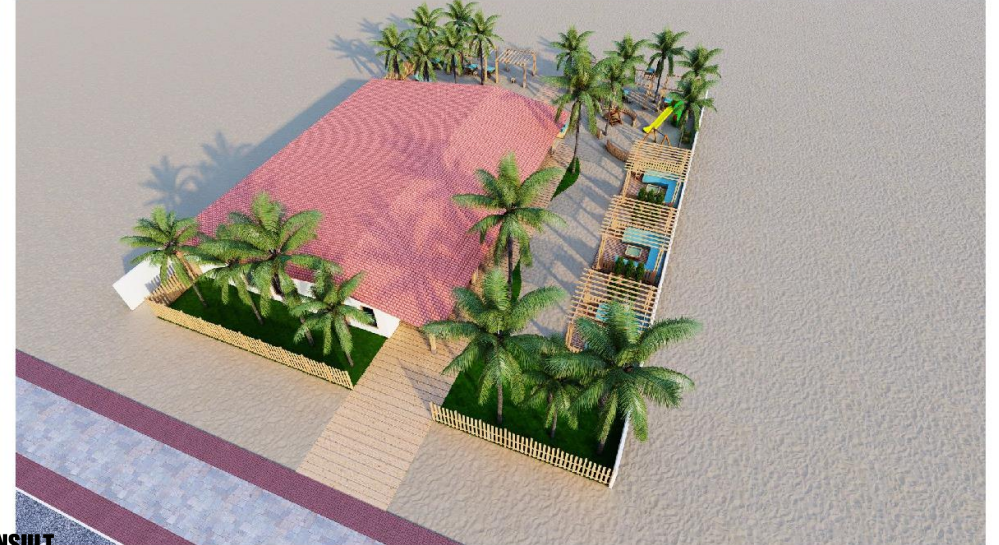

SARA CONSULT

Architectures & Ingénieries



MODELE 03

PAILLOTE INTEGRALE

- Pailote
- Salle fermée
- Terrasse en façade urbaine**
- Toilette & cuisine intégrées sous la pailote
- Toilettes isolées

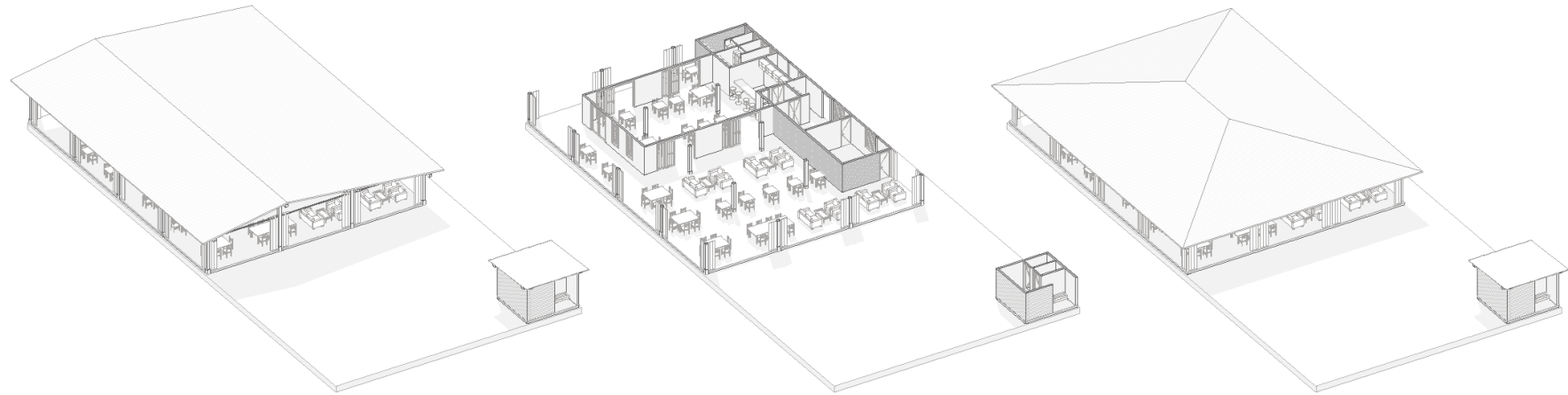

SARA CONSULT

Architectures & Ingénieries

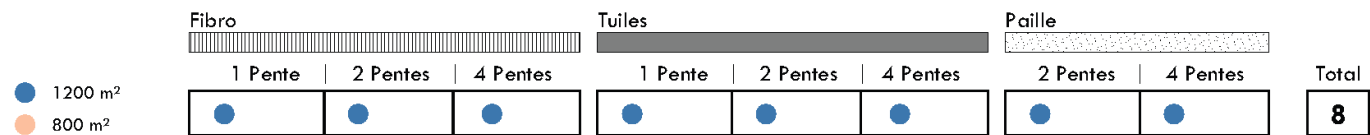

CONCEPT ARCHITECTURAL

- M01
- M02
- M03
- M04
- M05
- M06
- M07
- M08
- M09

MODELE 3

Paillote
Salle fermée
Terrasse en façade urbaine
Toilette & cuisine intégrées sous la paillote



MODELE 3

Toiture 4 Pentes
Tuiles Rouges

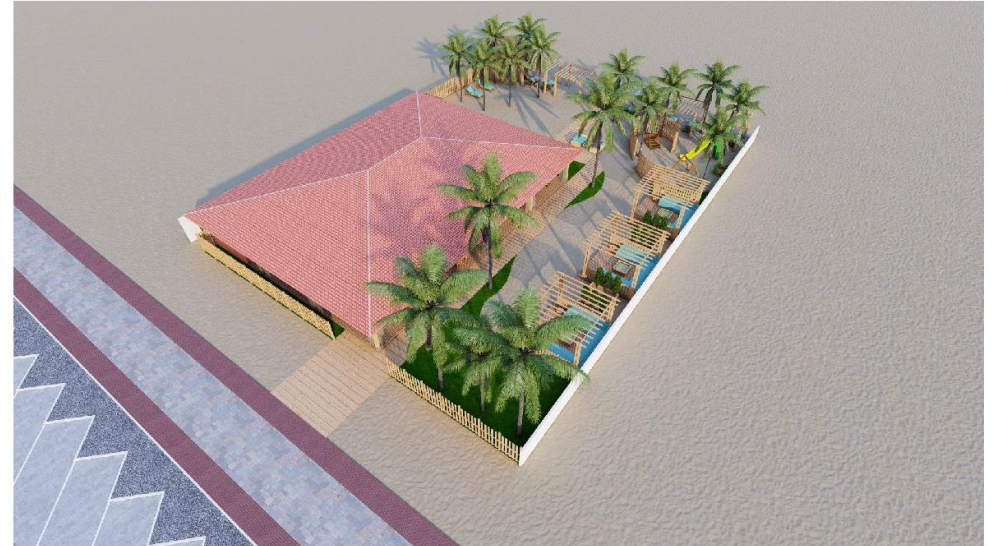

MODELE 04

PAILLOTE INTEGRALE

Paillote
Bar
 Jardin en façade Urbaine
 Toilette & cuisine intégrées
 sous la paillote

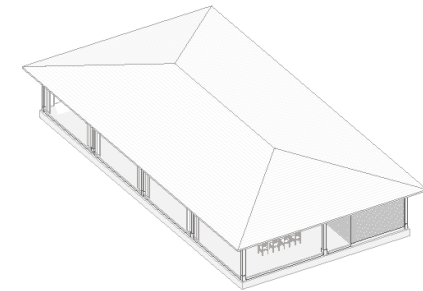
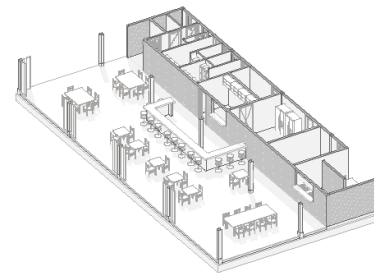
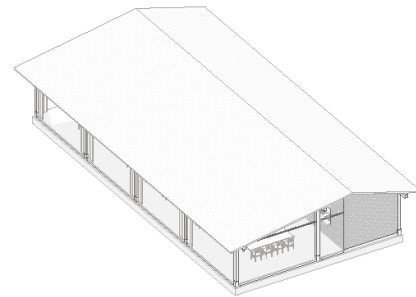

Fibro			Tuiles			Paille		Total
1 Pente	2 Pentes	4 Pentes	1 Pente	2 Pentes	4 Pentes	2 Pentes	4 Pentes	
● 1200 m ² ● 800 m ²	● 1200 m ² ● 800 m ²	● 1200 m ² ● 800 m ²	● 1200 m ²	● 1200 m ² ● 800 m ²	● 1200 m ² ● 800 m ²	● 1200 m ² ● 800 m ²	● 1200 m ² ● 800 m ²	15

MODELE 4

Paillote

Bar

Jardin en façade Urbaine

Toilette & cuisine intégrées sous la paillote



MODELE 4

Toiture 4 Pentes
Tuiles Rouges



SARA CONSULT

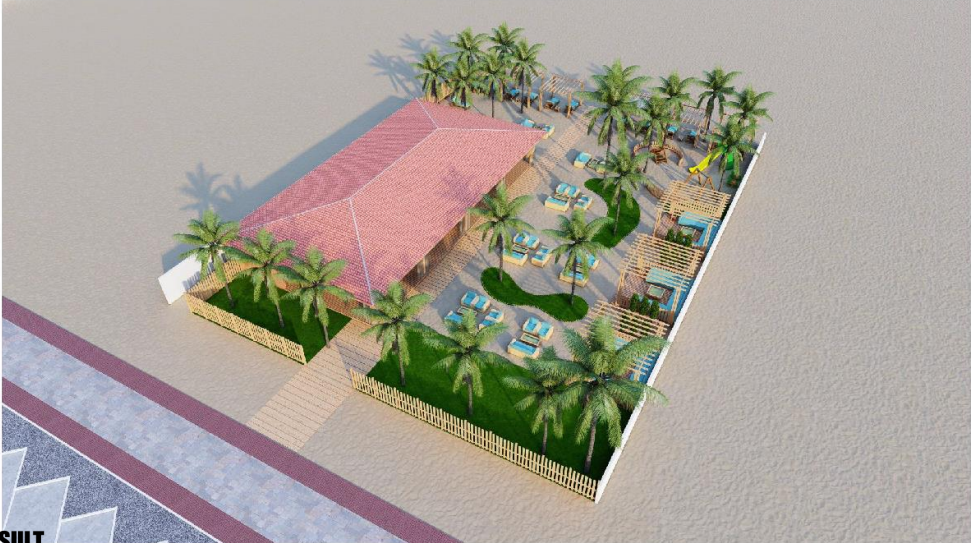

Architectures & Ingenieries



MODELE 05

ELEMENTS ISOLES

Paillote Carrée
Salle fermée
Toilette & cuisine détachées

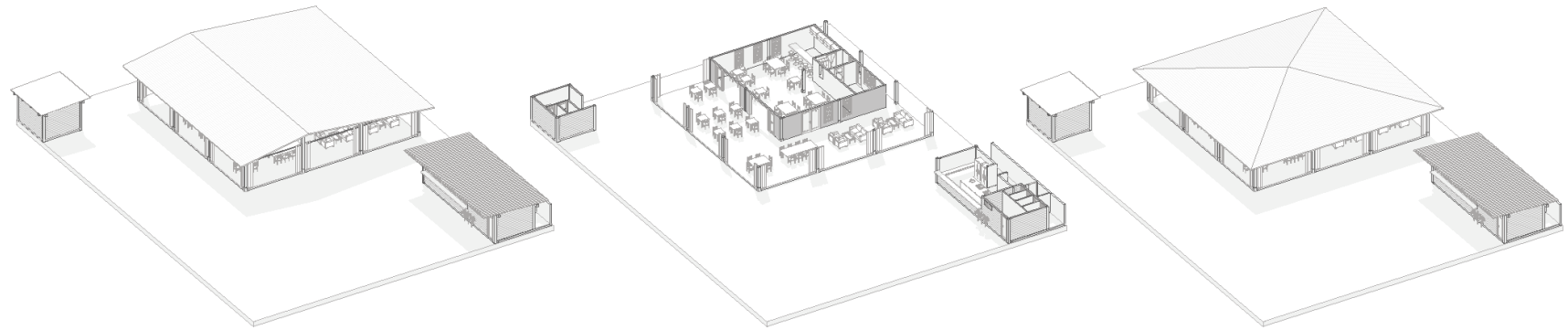

Fibro			Tuiles			Paille		Total
1 Pente	2 Pentes	4 Pentes	1 Pente	2 Pentes	4 Pentes	2 Pentes	4 Pentes	
●	●	● ●	●	●	●	●	●	9

● 1200 m²
● 800 m²

MODELE 5

Paillote Carrée
Salle fermée

Toilette & cuisine détachées

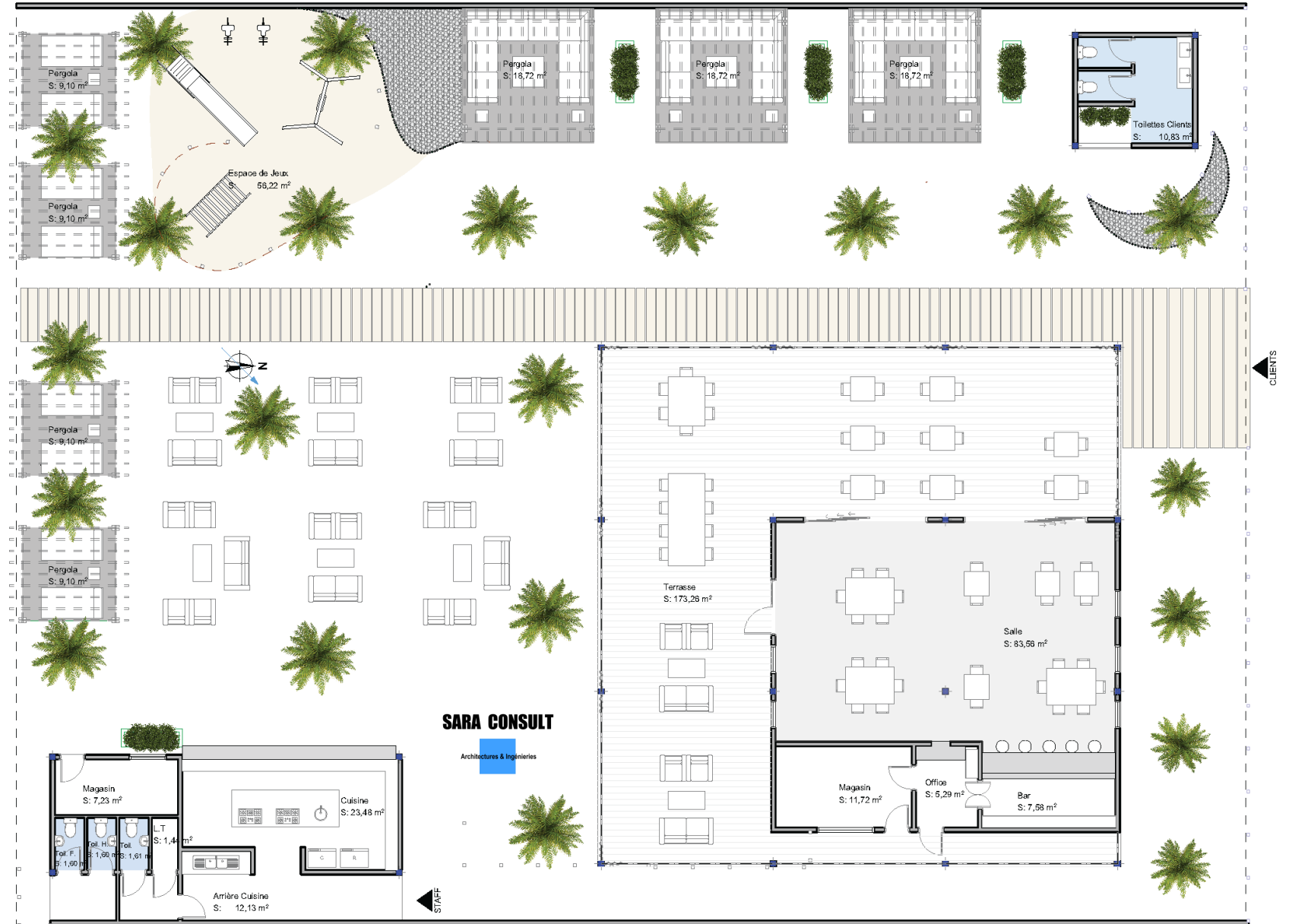

MODELE 5

Toiture 1 Pente
Paille



SARA CONSULT

Architectures & Ingenieries



MODELE 06

ELEMENTS ISOLES

Paillote
Toilettes et cuisine détachées

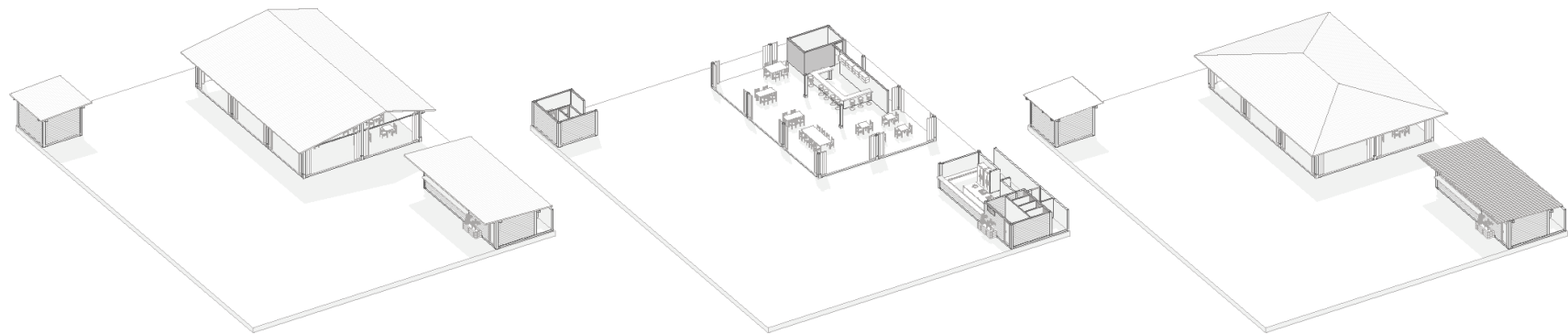

Fibro			Tuiles			Paille		Total
1 Pente	2 Pentes	4 Pentes	1 Pente	2 Pentes	4 Pentes	2 Pentes	4 Pentes	
●	●	● ●	●	●	●	●	●	9

● 1200 m²
● 800 m²

MODELE 6

Paillote

Toilette & Cuisine Détachées



MODELE 6

Toiture 1 Pente
Paille



SARA CONSULT

Architectures & Ingenieries



MODELE 07

ELEMENTS ISOLES

Paillote sur 800m²
 Salle fermée
Toilette Détachée & cuisine
 Sous paillote

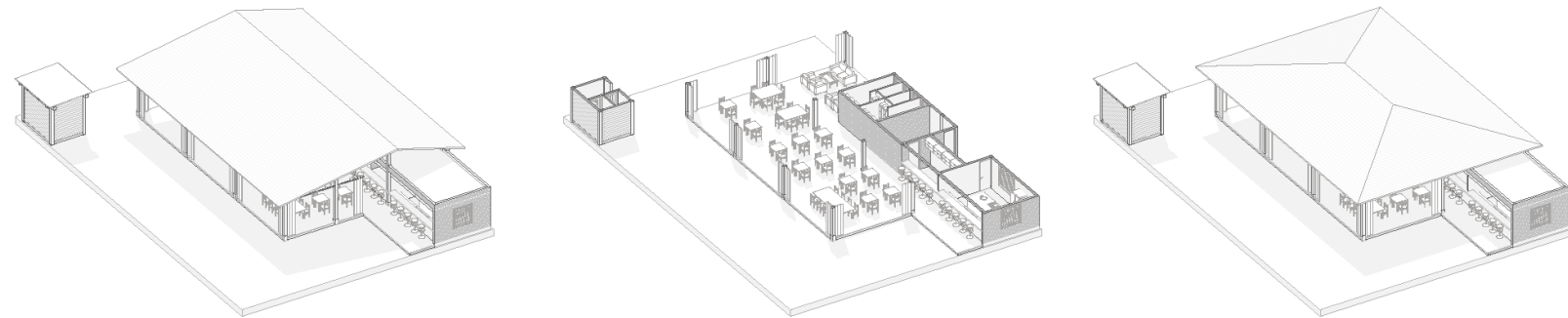

Fibro			Tuiles			Paille		Total
1 Pente	2 Pentes	4 Pentes	1 Pente	2 Pentes	4 Pentes	2 Pentes	4 Pentes	
●	●	● ●	●	●	●	●	●	15
●								

● 1200 m²
 ● 800 m²

MODELE 7

Paillote sur 800m²

Salle fermée

Toilette Détachée & cuisine Sous paillote



MODELE 08

ELEMENTS ISOLES

Paillote Transversale
Salle fermée
Toilette & cuisine isolées

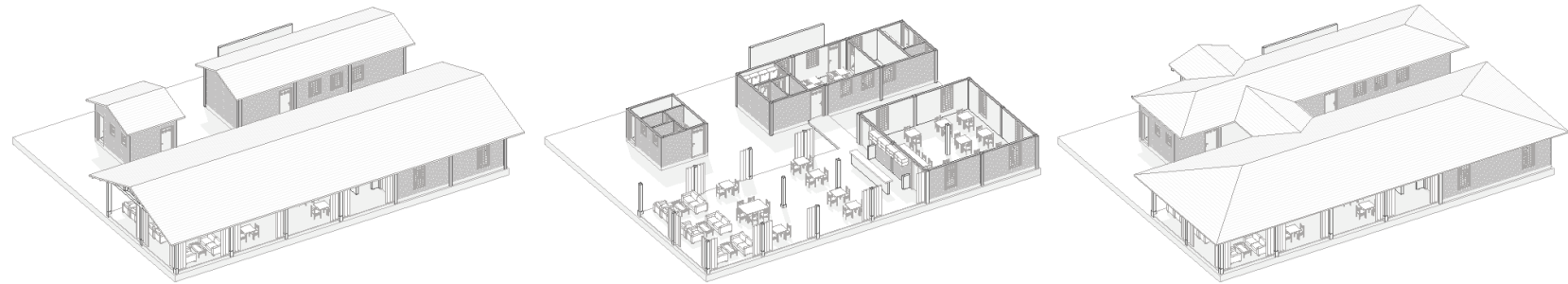

Fibro			Tuiles			Paille		Total
1 Pente	2 Pentes	4 Pentes	1 Pente	2 Pentes	4 Pentes	2 Pentes	4 Pentes	
●	●	●	●	●	●	●	●	10
○	○	○	○	○	○	○	○	

● 1200 m²

○ 800 m²

MODELE 8

Paillote Transversale

Salle fermée

Toilette & cuisine isolées



MODELE 8

Toiture 4 Pentes
Tuiles Rouges



SARA CONSULT

Architectures & Ingenieries



MODELE 8

Toiture 4 Pentes
Fibro Ciment



SARA CONSULT

Architectures & Ingénieries



MODELE 8

Paillote Transversale **800m²**

Salle fermée

Toilette & cuisine isolées



MODELE 8

Toiture 1 Pentes
Fibro



SARA CONSULT



Architectures & Ingenieries



MODELE 09

ELEMENTS ISOLES

Paillote centrale
Bar
 Toilette & cuisine détachées

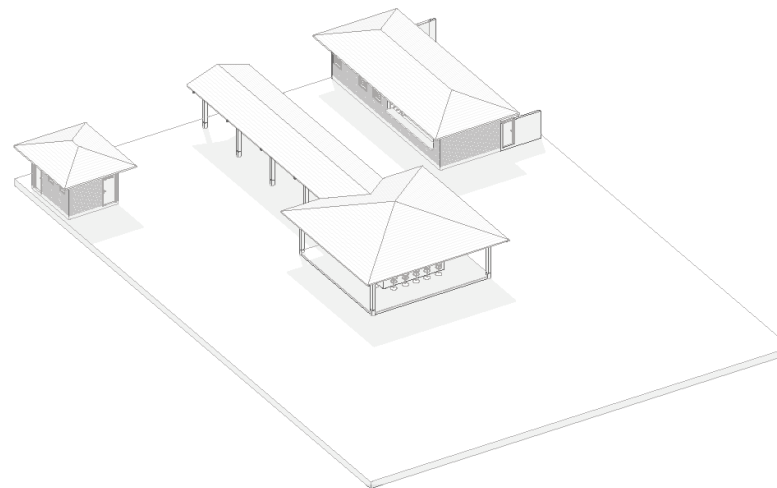

Fibro			Tuiles			Paille		Total
1 Pente	2 Pentes	4 Pentes	1 Pente	2 Pentes	4 Pentes	2 Pentes	4 Pentes	
		● ●			● ●		● ●	6

● 1200 m²
 ● 800 m²

MODELE 9

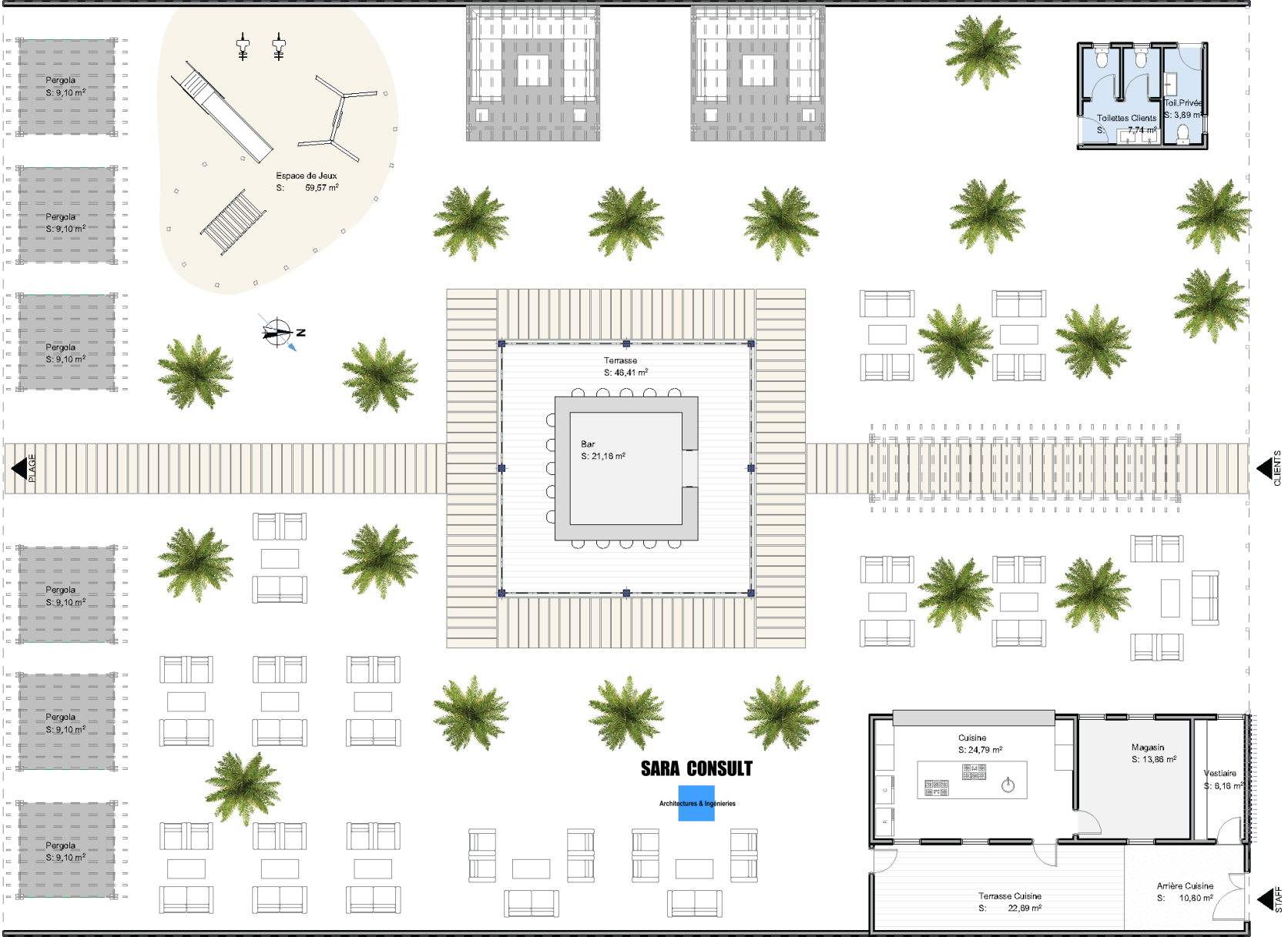

MODELE 9

Toiture 4 Pentes
Paille



MODELE 10



MODELE 10

Toiture dalle
Terrasse couverte



MODELE 11



MODELE 11

Toiture dalle
Roof Top



MODELE 12



A = 1200 m ²
B = 800 m ²

Tableau des Variantes

Couverture
Toiture
Parcelle

Modèle 1
Modèle 2
Modèle 3
Modèle 4
Modèle 5
Modèle 6
Modèle 7
Modèle 8
Modèle 9

Fibro						Tuiles						Paille			
1		2		4		1		2		4		2		4	
A	B	A	B	A	B	A	B	A	B	A	B	A	B	A	B
●	●	●	●	●	●	●		●	●	●	●	●	●	●	●
●		●		●		●		●		●		●		●	
●		●		●		●		●		●		●		●	
●	●	●	●	●	●	●		●	●	●	●	●	●	●	●
●		●		●	●	●		●		●		●		●	
●	●	●	●	●	●	●		●	●	●	●	●	●	●	●
●		●		●		●	●	●		●	●	●		●	
				●	●					●	●			●	●
8	3	8	3	9	6	8	1	8	3	9	5	8	3	9	4

15
8
8
15
9
9
15
10
6

95
